

APPENDIX:
PARTS DIAGRAMS AND REFERENCE
for

Cherrington

Model 4700XL

Serial Number: _____

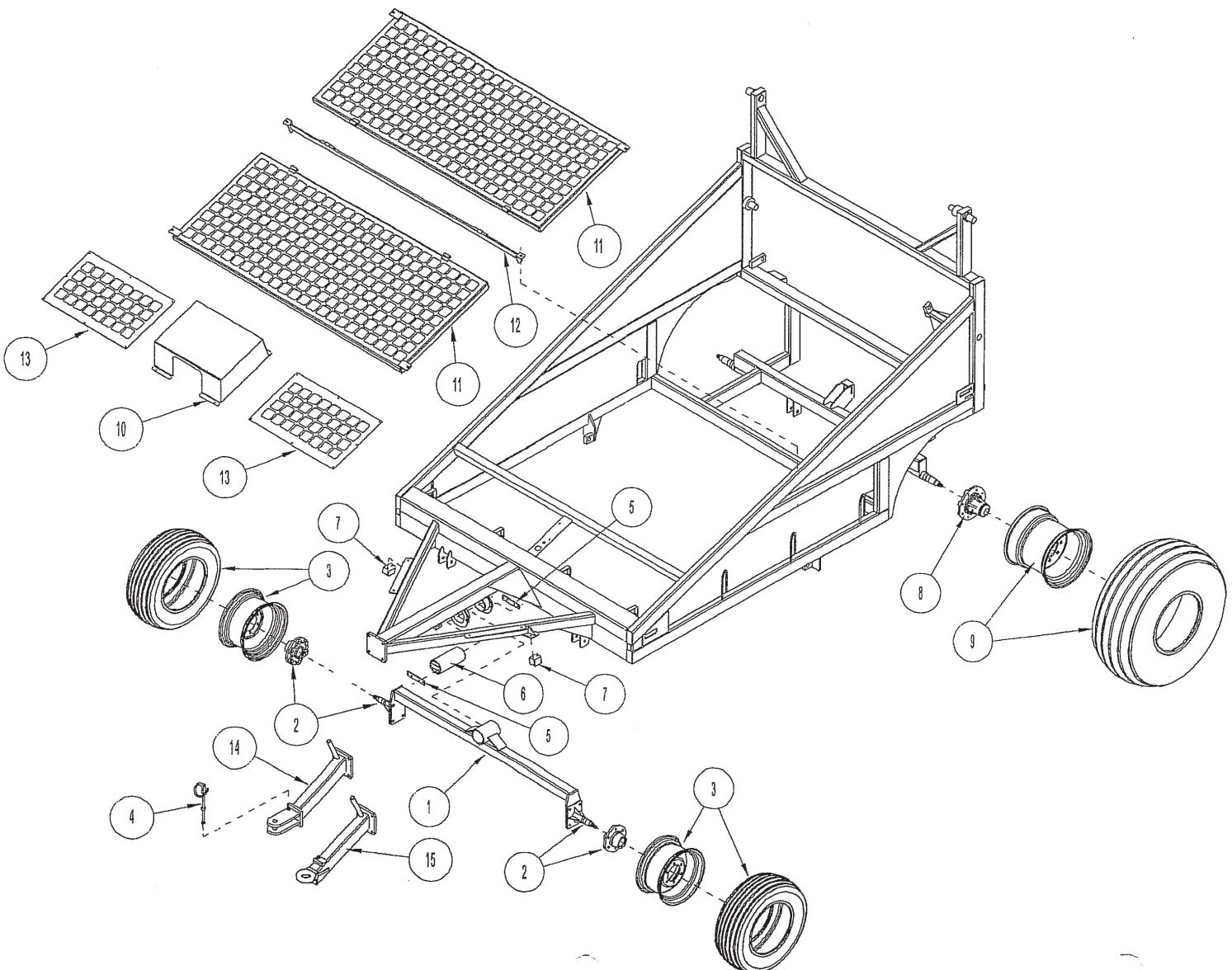

WHEEL ASSEMBLY PARTS REFERENCE

REF NO.	PART NO.	DESCRIPTION	QTY
1	470009	GAUGE AXLE BEAM	1
2	005201	AXLE ASSEMBLY: GAUGE WHEEL	2
3	005103	GAUGE WHEEL ASSY	2
	P750600	RIM: 15 X 8	2
	P763700	TIRE: 27 X 9.5-8	2
4	005313	HOSE LOOP ASSY; SLIDER	1
5	470105	RETAINER; AXLE PIVOT PIN	2
6	470106	PIVOT PIN; GAUGE AXLE	1
7	P133320	SHOCK BUMPER	2
8	005101	HUB ASSY, 8 BOLT	2
9	470119	WHL ASSY; 16.5 X 16.1	2
	P750800	RIM: PIONEER #106987	2
	P763450	TIRE; 16.5L X 16.1 SL	2
10	470137	SHIELD; VALVE COVER	1
11	470116	SHIELD; CONVEYOR	2
12	470118	HINGE BAR; CONV SHIELD	1
13	470136	SHIELD; CONV FRONT	2
14	470131	HITCH WELD; BOLT-ON CLEVIS	1
15	470132	HITCH WELD; BOLT-ON PINTLE (OPTIONAL)	1
	P120460	HITCH PIN: 1" X 6"	1
	P465200	CAT 2 CROSSBAR #10432	1
	P999000	BOX: OWNERS MANUAL	1

HYDRAULIC SYSTEM DIAGRAM

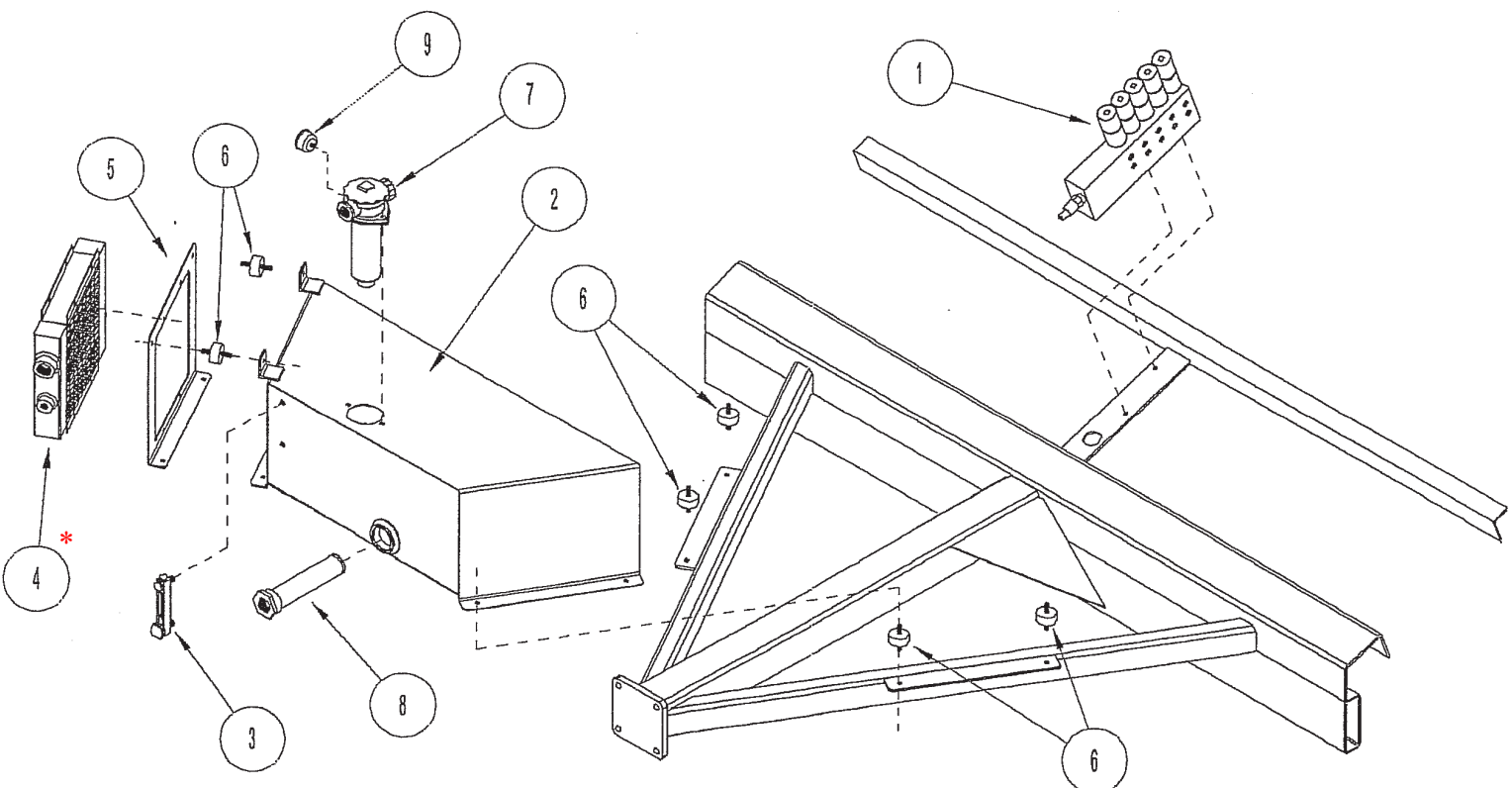

HYDRAULIC SYSTEM PARTS REFERENCE

REF NO.	PART NO.	DESCRIPTION	QTY
1	P292200	VALVE ASSY; 6 BANK 04-0699A-ASY	1
2	470047	OIL TANK 4700	1
3	P297220	GAUGE: OIL SIGHT	1
4*	P117300	COOLER: HYD OIL AKG DC16-12	1
5	470073	COOLER BRACKET	1
6	P133030	RUBBER MT: 7/8"	6
7	P371920	FILTER; TANK TOP	1
	P371925	FILTER ELEMENT	1
8	P780100	STRAINER: HYD OIL	1
9		RESTRICTION INDICATOR	1
	P556600	PUMP; EATON PTO 77022-LAH (not pictured)	1

*NOT SHOWN: 71.P117310 COOLING FAN ONLY

PTO PUMP

PLANETARY GEARBOX DRIVE / HYDRAULIC GEAR PUMP

- 1) 71.P556600 COMPLETE PUMP ASSEMBLY (PLANETARY GEARBOX / HYDRAULIC GEAR PUMP FULLY ASSEMBLED)
- 2) 71.P556610 HYDRAULIC GEAR PUMP (GEAR PUMP SECTION ONLY)
- 3) 71.P556611 HYDRAULIC GEAR PUMP SEAL KIT
- 4) 71.V16253-34 PTO / PLANETARY GEARBOX INPUT SHAFT SEAL
- 5) 71.V160.15 O RING

HYDRAULIC GEAR PUMP SECTION

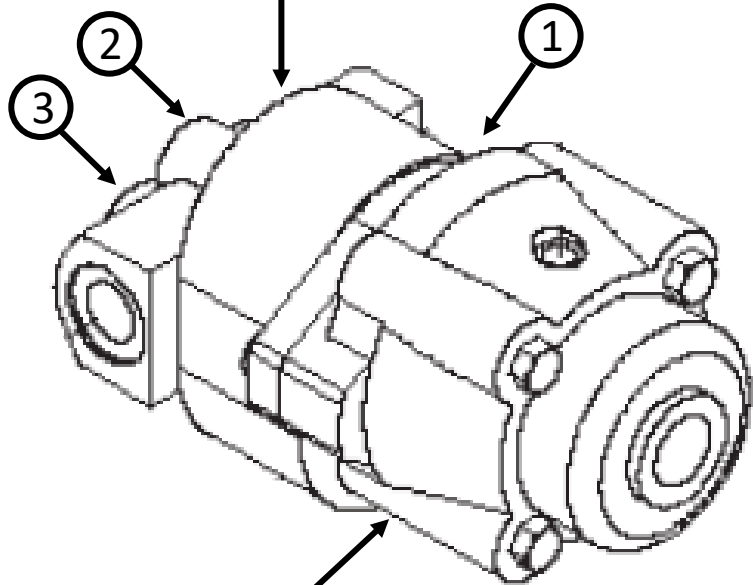

PLANETARY GEARBOX DRIVE SECTION

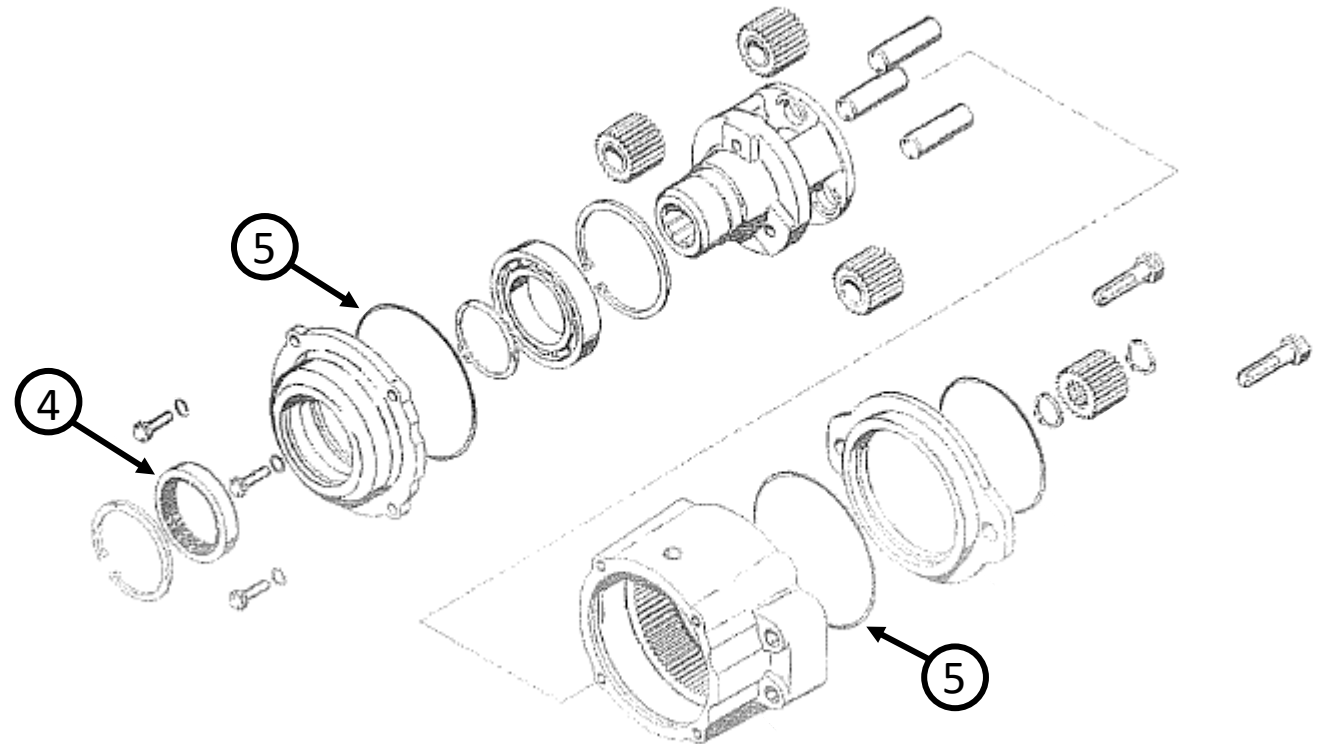

PLANETARY GEARBOX DRIVE EXPLODED VIEW

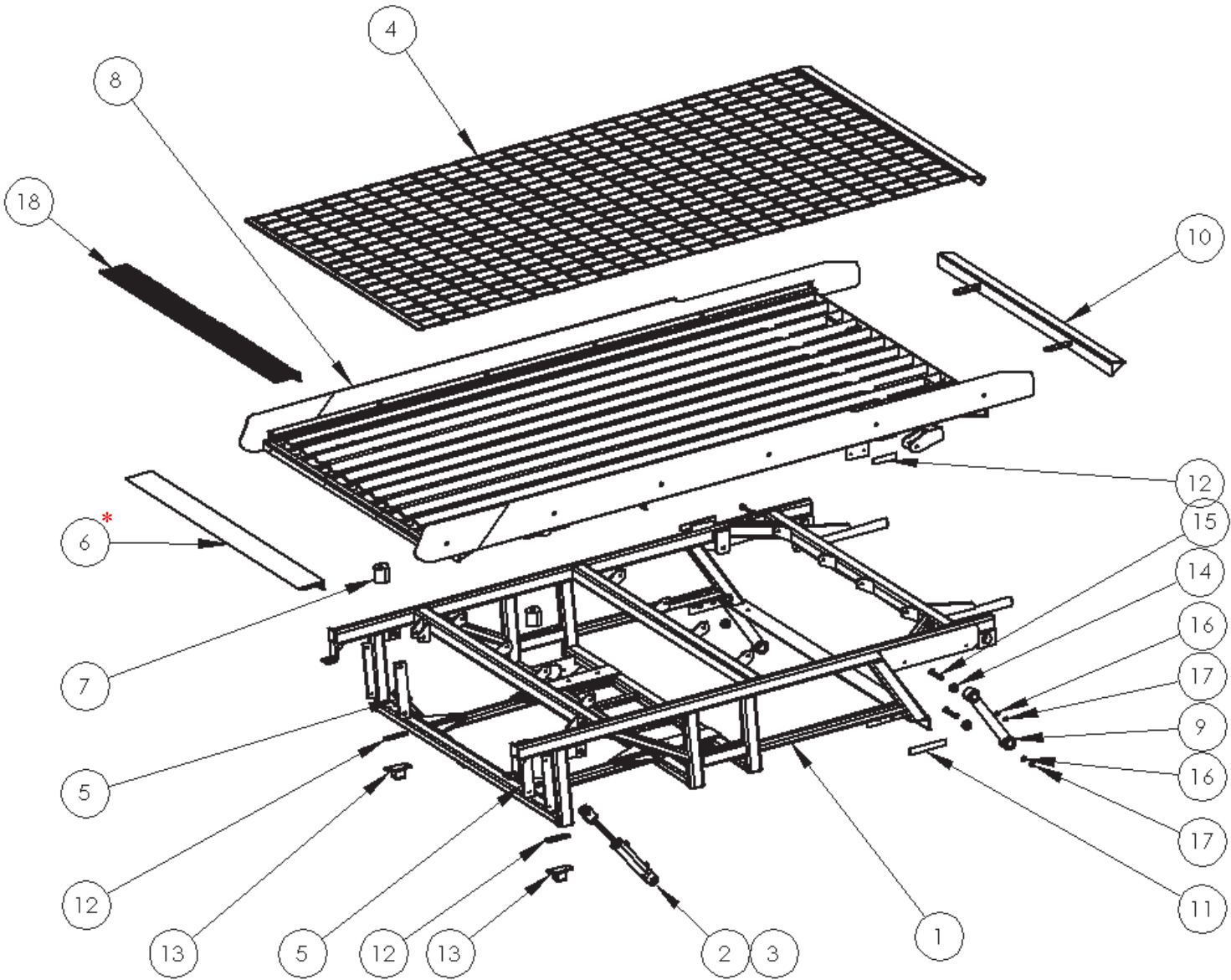

SCREEN FRAME PARTS REFERENCE

Item #	Part Number	Description	QTY
1	470216	SCREEN FRAME HANGER	1
2 *	P259305	CYL: 2B X 10 S W/CAV CH (INCL. ITEM 3)	2
3	P259306	SEAL KIT: CYL RKT 2-0096	2
4	470099	SCREEN: ¾"	1
5	000271M	WEAR STRIP	2
6 *	470173	CUTTING EDGE WLD 4700	1
7	P133075	ISOLATOR MT: J 5425-275	2
8	470207	SCREEN FRAME 4700	1
9	470217	ROCKER ARM 14"	2
10	470208	TENSION BAR WLD: SCREEN	1
11	470231	WEAR PAD: 2-1/4" X 8"	2
12	470160	WEAR PAD: 2-1/4" X 5"	4
13	470159	BRKT: COMPRESSION LIMITER	2
14	P126820	BUSHING: RUBBER	4
15	P100818	BOLT: 1/2-13 NC X 4-1/2	4
16	P851108	WASH: LOCK 1/2"	4
17	P155850	NUT: 1/2 TOP LOCK	4
OPTIONAL:			
18	470174	SLOTTED CUTTING EDGE	1

* #2 P259305 CYLINDER USES PILOT OPERATED LOAD CHECK QTY 1 PER CYLINDER
71.P294250 (NOT INCLUDED WITH CYLINDER)

* NOT SHOWN: CUTTING EDGE MOUNTING HARDWARE
QTY 4 71.P100605 3/8-16 X 1-1/4 GR 5 HEX BOLT
QTY 4 71.P851106 3/8 LOCK WASHER
QTY 4 71.P150600 3/8-16 GR 5 HEX BOLT

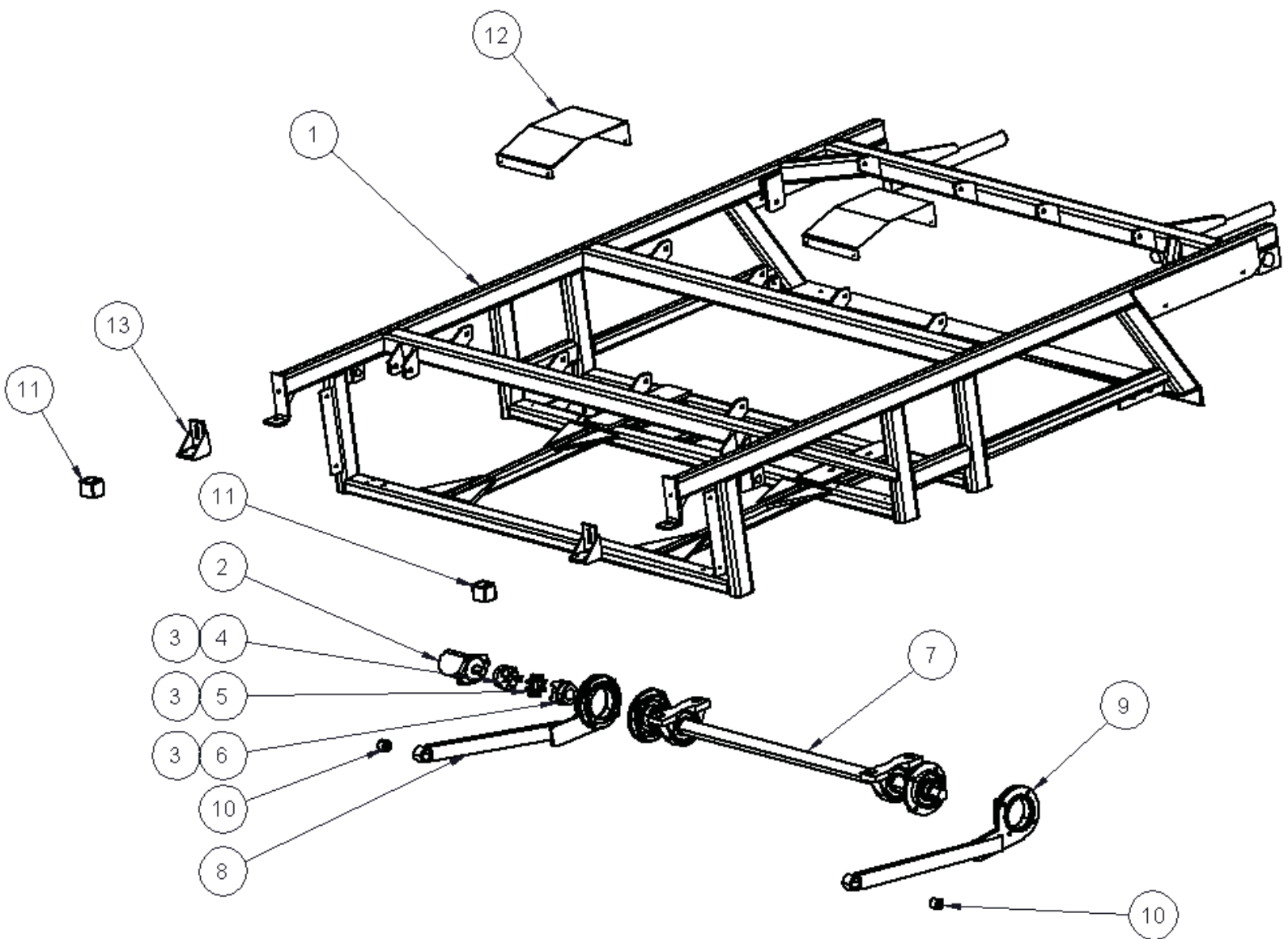

SCREEN DRIVE PARTS REFERENCE

Item #	Part Number	Description	QTY
1	470216-A	SCREEN FRAME HANGER	1
2	P353400	MTR: C/L 158-1537 4.0 CID	1
3	P272910	CPLG ASSY: 38/45 (INCL. ITEMS 4, 5, 6)	1
4	P272912	COUPLER Y HALF, 38-1b	1
5	P272911	COUPLER SPIDER INSERT, 38 SERIES	1
6	P272913	COUPLER HALF, 38-1.5B	1
7	470077	PITMAN SHAFT ASSY	1
8	470074	PITMAN ARM RIGHT	1
9	470075	PITMAN ARM LEFT	1
10	P126840	BUSHING: RUBBER J6424-1	2
11	P133320	SHOCK BUMPER	2
12	470223-4	SHIELD: PITMAN BEARING	2
13	470071	BRKT: FRONT SHAFT ADJ	2

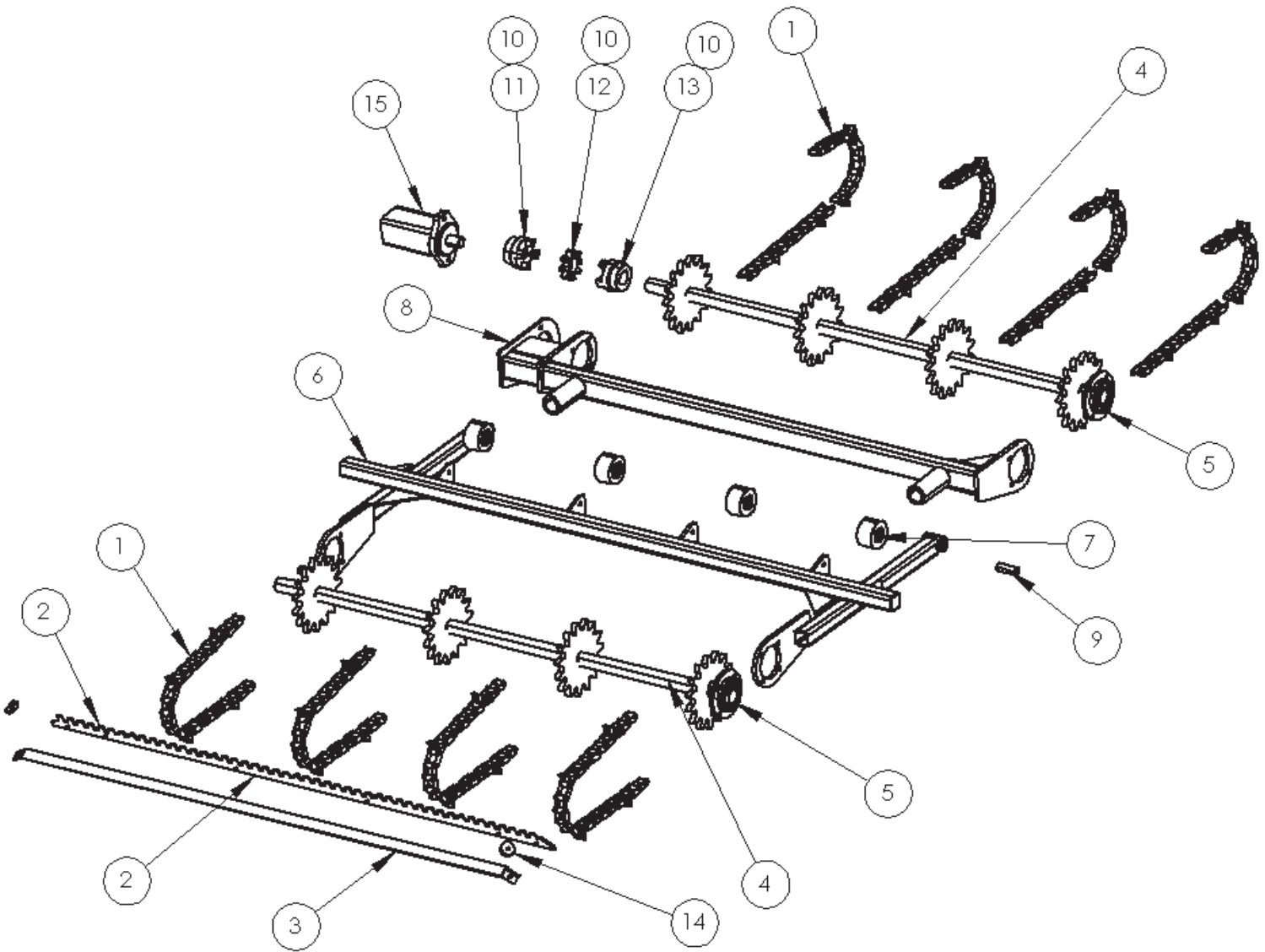

CONVEYOR SYSTEM PARTS REFERENCE

Item #	Part Number	Description	QTY
1	P632500	CHAIN: #620 CONV 31 CLT	4
2	470170	FLIGHT BLADE 4700	31
3	470080	FLIGHT ANGLE 4700	31
4	470044	SHAFT WELD: 4700 CONV	2
5	P003115	BEARING: S/M #MFC-28 3C	4
6	470034	CONVEYOR SUPPORT 4700	1
7	P761100	SNUGULATOR 2500 BD 1X	16
8	470081	SHAFT MOUNT REAR	1
9	470123	BUSHING: 1" X 5/8" X 2-5/8"	2
10	P272970	COUPLER ASSEMBLY	1
11	P272972	COUPLER HALF: 42-1.25B	1
12	P272971	CPLG SPIDER INSERT: 42 SERIES	1
13	P272973	COUPLER HALF: 42-1.75B	1
14	470130	FLIGHT PUCK	62
15	P353500	MTR: C/L 104-1206 18.7 CID	1

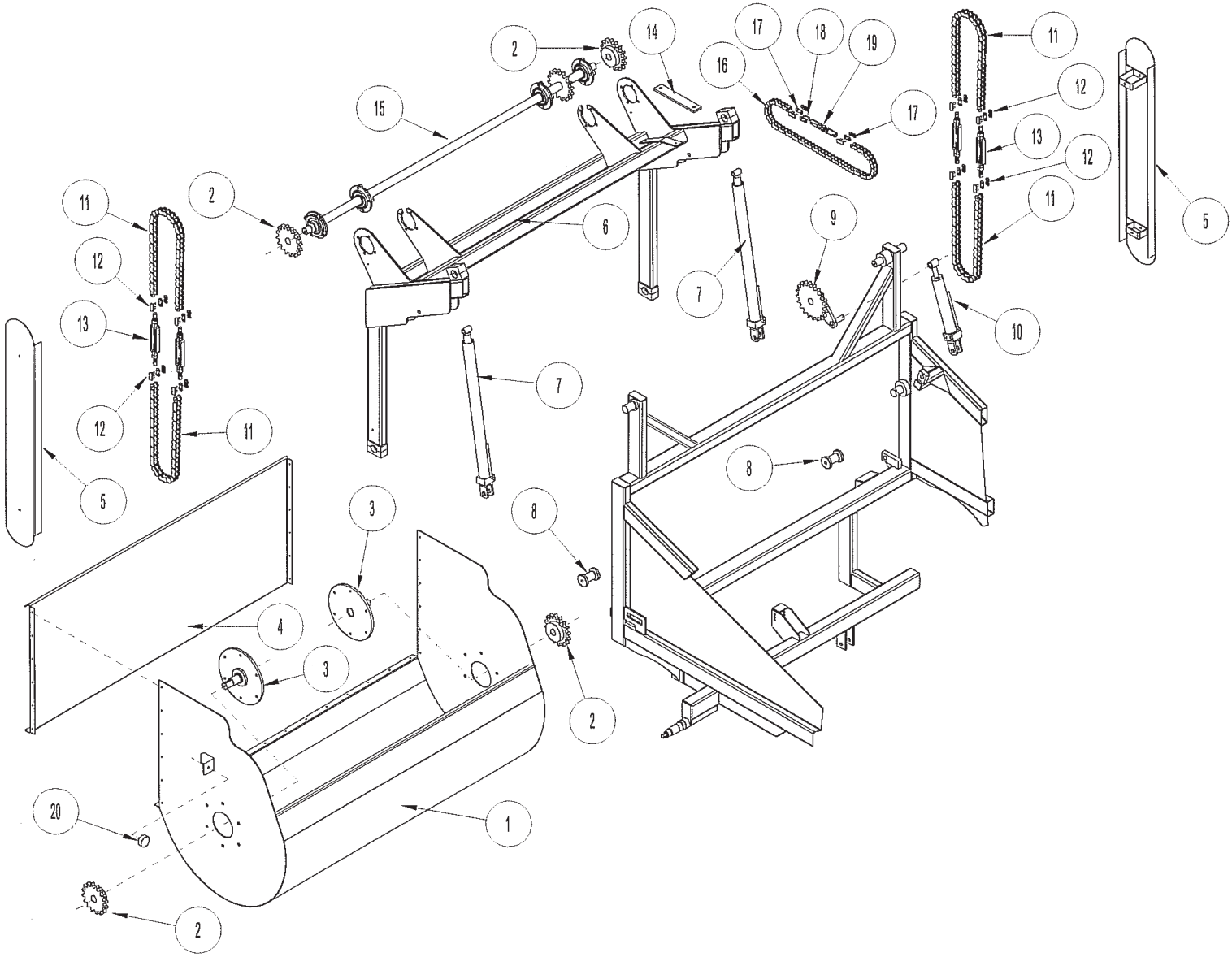

HOPPER AND ROLLOVER PARTS REFERENCE

Item #	Part Number	Description	Quantity
1	470064	HOPPER BODY	1
2	P690818	SPROCKET: H1BF80-018-1.5	4
3	470053	HOPPER DRIVE PLATE	2
4	470206	HOPPER BACK	1
5	470095	ROLLOVER CHAIN GUARD	2
6	470039	BOOM 4700	1
7 *	P259360	CYLINDER; 2.5B X 28S W/CAV CH	2
8	P761000	ROLLER; 4" KEEL	2
9	470061	HOPPER CRANK 4700	1
10 *	P259370	CYLINDER; 2B X 9.75S W/CAV CH	1
11	470140	CHAIN: HOPPER DRIVEN #80 <i>(Includes 2 of Item #12)</i>	4
12	P630301	CONNECTING LINK #80	8
13	470144	TURNBUCKLE ASSY 3/4" SHORT	4
14	000271M	WEARSTRIP, CONV	1
15	470139	DRIVE SHAFT ASSY: HOPPER	1
16	470121	CHAIN: HOPPER R/O 4700 <i>(Includes 2 of Item #17 and 1 of Item #18)</i>	1
17	P630100	CHAIN LINK: #100 CONNECTOR	2
18	P630101	CHAIN LINK: #100 OFFSET	1
19	470142	TURNBUCKLE ASSY 3/4 JACKSCREW	1
20	000358M	STOP, RUBBER	1

* #7 AND #10 CYLINDER USE PILOT OPERATED LOAD CHECK QTY 1 PER CYLINDER 71.P294250 (NOT INCLUDED WITH CYLINDER)

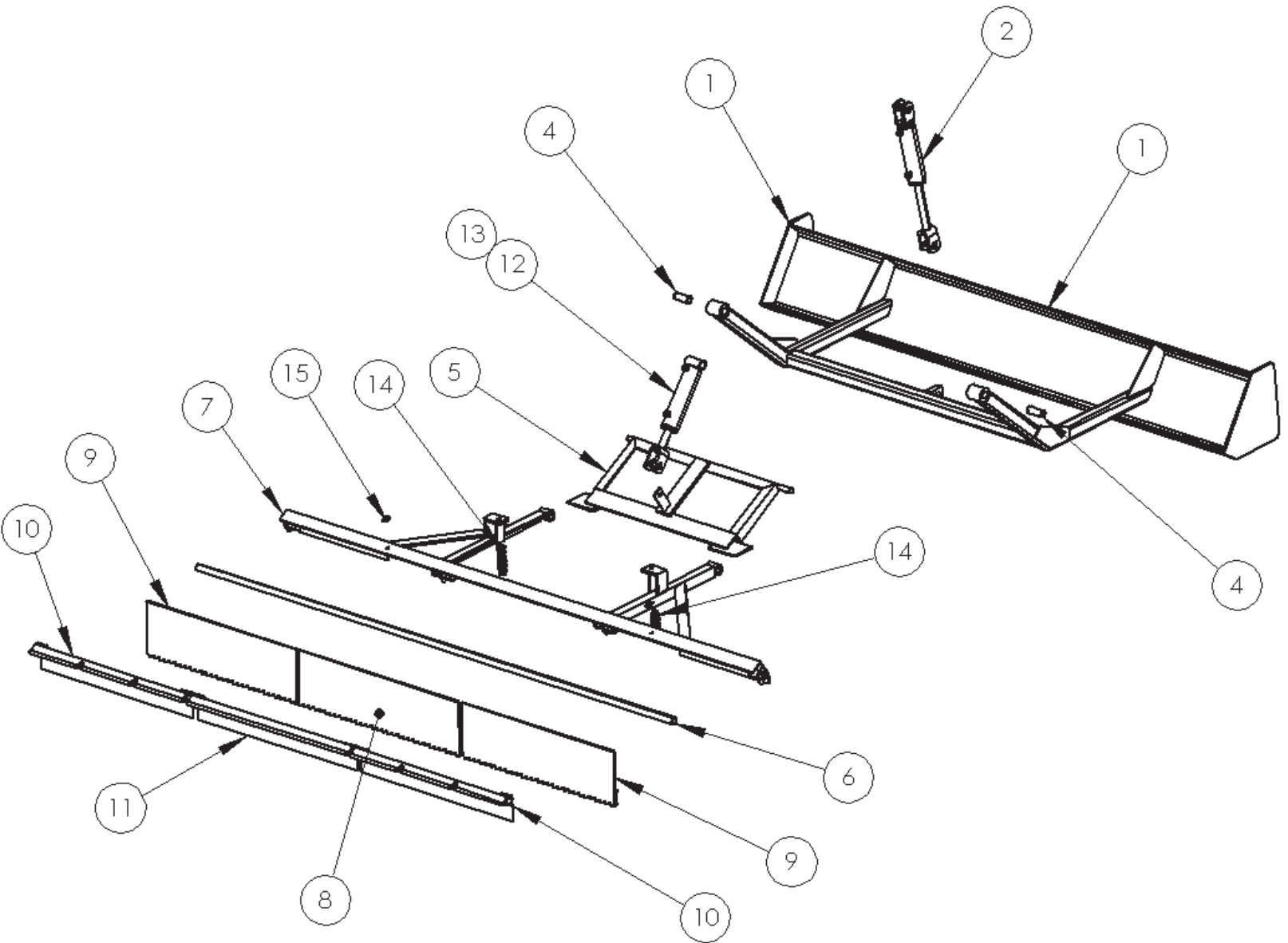

LEVELER AND GROOMER PARTS REFERENCE

Item #	Part Number	Description	Quantity
1	470314	LEVELING BLADE	1
2 *	P259380	CYL: 1.5B X 6S W/CAV CH (INCL. ITEM 3)	1
3	P259151	SEAL KIT: CYL RKT 1.5-0047	1
4	470123	BUSHING: 1" X 5/8" X 2-5/8"	2
5	004864	LIFT BRACKET, GROOMER	1
6	004229	COMB BRKT MOUNT PIPE	1
7	004862	GROOMER BAR	1
8	005337	GROOMER COMB, CENTER	1
9	005338	GROOMER COMB, OUTSIDE	2
10	005340	GROOMER BRKT, OUTSIDE	2
11	005339	GROOMER COMB, CENTER	1
12	P259160	CYLINDER, GROOMER (INCL. ITEM 13)	1
13	P259306	SEAL KIT: CYL RKT 2-0096	1
14	P605700	SPRING, DIE 5"	2
15	004883	WEAR PAD, GROOMER	2

* #2 HYDRAULIC CYLINDER USES PILOT OPERATED LOAD CHECK QTY 1 PER CYLINDER
71.P294250 (NOT INCLUDED WITH CYLINDER)

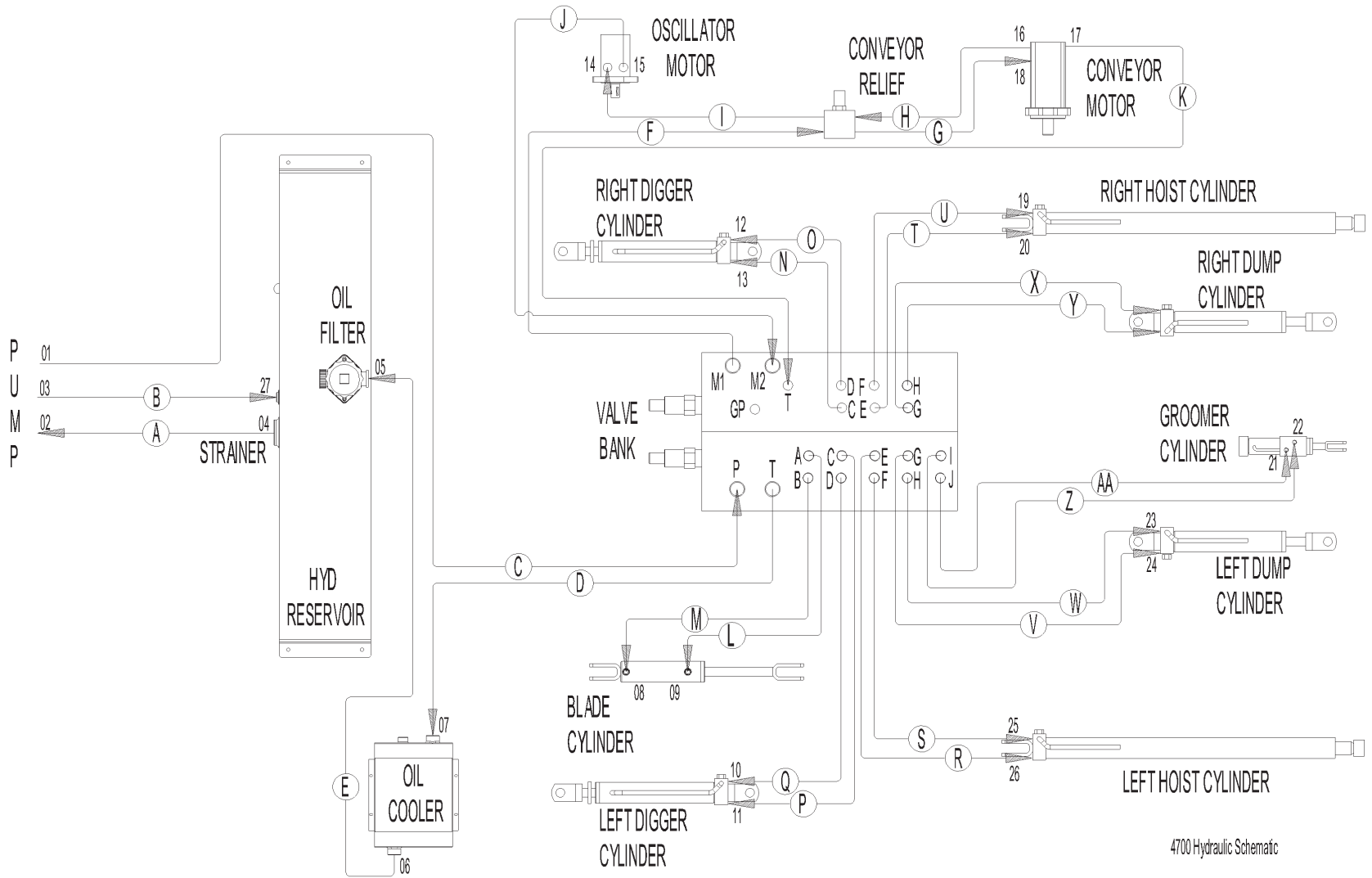

4700 Hydraulic Schematic

HYDRAULICS LEGEND

- A. 20MJ-20MP, P289993, 20MJ-20MB
- B. 6MJ-6MB90, P283099, 6MJ-6MP
- C. 10MJ-12MB, P285918, 10MJ-10MB90
- D. 12MJ-10MB, P286940, 12MJ-16MB
- E. 12MJ-16MB, P286959, 12MJ-16MB90
- F. 10MJ-10MB, P285136, 10MJ-10MB
- G. 10MJ-10MB, P285990, 10MJ-10MB45
- H. 10MJ-10MB45, P285990, 10MJ-10MB
- I. 10MJ-10MB, P285030, 10MJ-10MB90
- J. 10MJ-10MB, P285939, 10MJ-10MB45
- K. 4MJ-4MB90, P282437, 4MJ-6MB
- L. 4MJ-6MB, P282946, 4MJ-6MB90
- M. 4MJ-6MB .035R, P282946, 4MJ-6MB90
- N. 6MJ-6MB45 .100R, P283158, 6MJ-6MB90
- O. 6MJ-6MB45, P283158, 6MJ-6MB90
- P. 6MJ-6MB45 .100R, P283158, 6MJ-6MB90
- Q. 6MJ-6MB45, P283158, 6MJ-6MB90
- R. 6MJ-6MB45, P283209, 6MJ-6MB90
- S. 6MJ-6MB45 .100R, P283209, 6MJ-6MB90
- T. 6MJ-6MB45, P283209, 6MJ-6MB90
- U. 6MJ-6MB45 .100R, P283209, 6MJ-6MB90
- V. 6MJ-6MB45, P283184, 6MJ-6MB90
- W. 6MJ-6MB45 .045R, P283184, 6MJ-6MB90
- X. 6MJ-6MB45, P283184, 6MJ-6MB90
- Y. 6MJ-6MB45 .045R, P283184, 6MJ-6MB90
- Z. 4MJ-6MB45 .035R, P282201, 4MJ-4MB90
- AA. 4MJ-6MB45, P282201, 4MJ-4MB90
- GP. PD361 NIPPLE

ELECTRICAL LEGEND

The EA-1067 control box has six toggle switches. It includes auto up/down function for the Groomer and when the forward Conveyor is turned on the fan and hour meter will be activated.

<u>WIRE COLOR</u>	<u>FUNCTION</u>	<u>PIN</u>
Green	Fan Power (1 of 2)	A
White/Red	Fan Power (2 of 2)	R
Blue	Conveyer Forward	C
White	Conveyer Reverse	E
White/Black	Digger Raise	F
Red	Digger Lower	H
Black/Red	Hopper Raise	J
Blue/White	Hopper Lower	K
Green/White	Hoist Raise	L
Black/White	Hoist Lower	N
Blue/Black	Groomer Raise	O
Green/Black	Groomer Lower	P
Red/Black	Level Blade Raise	Q
Orange/Red	Level Blade Lower	S
Black	Ground	B
Orange	Ground	D
Orange/Black	Ground	G
Red/White	Ground	M
Brown (Betts)	12 VDC Power	
White (Betts)	Ground	

ELECTRICAL CONTROL ITEMS NOT SHOWN IN PARTS BOOK:

- 71.P292050 CONTROL BOX
- 71.P292100 MAIN HARNESS / CONTROL CABLE
- 71.470317 POWER SUPPLY CABLE