

GENERAL ASSEMBLY

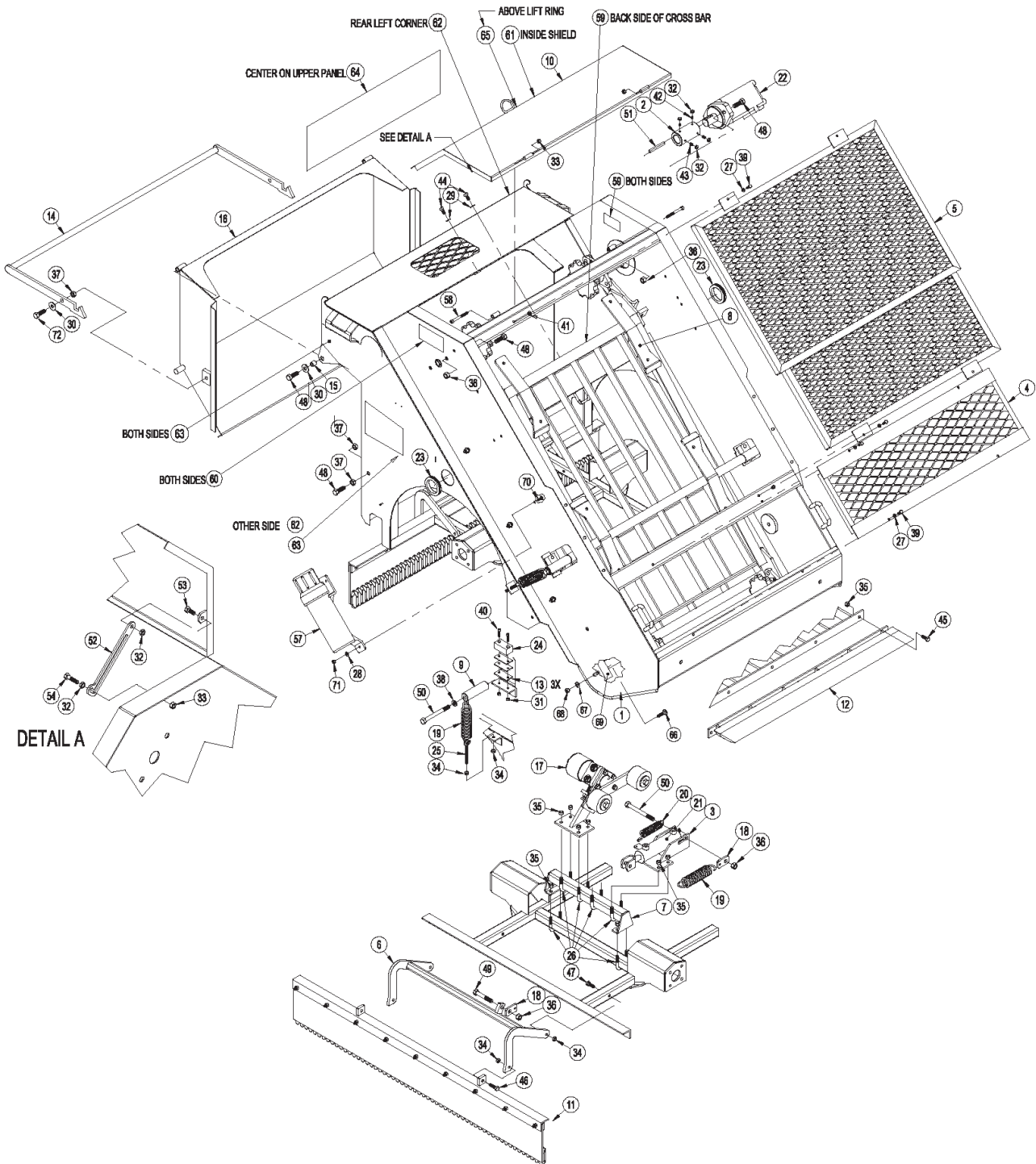

GENERAL ASSEMBLY

<u>Item</u>	<u>Qty</u>	<u>Part ID</u>	<u>Part Description</u>	<u>Item</u>	<u>Qty</u>	<u>Part ID</u>	<u>Part Description</u>
1	1	M30173	WELDMENT: MAIN FRAME	55	1	M30184	SCREEN: WOVEN, 1/2"
2	1	M30022	COUPLER: CONVEYOR SHAFT	56	1	M30185	SCREEN: WOVEN, 3/4"
3	1	M30023	MOUNT: CYLINDER, REAR	57	1	P136000	TUBE: MANUAL
4	1	M30047	SHIELD: FRONT, LOWER	58	2	P110512	SCREW: CAP, SCKT HD, 5/16"X3"
5	1	950002	SHIELD: FRONT, UPPER	59	3	P975107	DECAL: DANGER SHLD MISSING
6	1	M30067	FRAME: LIFT	60	2	P977910	DECAL: DANGER KEEP CLEAR
7	1	M30110	BRACKET: CONVEYOR RISER	61	1	P977900	DECAL: WARNING, GUARDS
8	1	M30074	ASSEMBLY: CONVEYOR	62	1	P970001	DECAL: CHERR. RIGHT
9	2	M30075	CONVEYOR: HOLD DOWN	63	2	P970002	DECAL: CHERR. LEFT
10	1	M30070	SHIELD: REAR	64	1	P970003	DECAL: CHERR REAR
11	1	M30182	ASSEMBLY: DRAG	65	1	P970300	DECAL: DANGER ROTATING PT
12	1	M30172	POINT: DIGGER	66	8	P104605	BOLT: CARRIAGE, 3/8" X 1 1/4"
13	6	M30079	SPACER: BUMPER	67	8	P850106	WASHER: FLAT, 3/8"
14	1	M30080	HANDLE: HOPPER DOOR	68	8	P150601	NUT: HEX, 3/8"
15	2	M30081	BUSHING: LATCH PIVOT	69	2	M30178	SCREEN GUIDE
16	1	M30082	WELDMENT: HOPPER	70	3	P104403	BOLT: CARRIAGE, 1/4" X 3/4"
17	1	M30085	ASSEMBLY: SEPARATOR	71	3	P150400	NUT: HEX, 1/4"
18	2	M30147	HOLDER: SPRING	72	2	P100807	BOLT: HEX, 1/2" X 1 3/4"
19	3	P601500	SPRING: EXTENSION				
20	1	P604700	SPRING: EXTENSION				
21	1	P259150	CYLINDER: HYDRAULIC, 1 1/2" X 4"				
22	1	P350700	MOTOR: HYDRAULIC, CHAR-LYNN 2000				
23	2	P133060	GROMMET: RUBBER				
24	2	P605000	PAD: BUMPER				
25	2	P135101	BOLT: EYE, 3/8"				
26	6	P127204	U-BOLT: 3/8" X 1 1/2" X 2 1/4"				
27	8	P851104	WASHER: LOCK, 1/4"				
28	3	P850104	WASHER: FLAT, 1/4"				
29	2	P850105	WASHER: FLAT, 5/16"				
30	4	P850107	WASHER: FLAT, 7/16"				
31	4	P158003	NUT: NYLOCK, 1/4"				
32	6	P155300	NUT: JAM, 5/16"				
33	3	P155350	NUT: TOP LOCK, 5/16"				
34	8	P155400	NUT: JAM, 3/8"				
35	17	P155450	NUT: TOP LOCK, 3/8"				
36	6	P155850	NUT: TOP LOCK, 1/2"				
37	6	P157200	NUT: JAM, 1/2"				
38	2	P851108	WASHER: LOCK, 1/2"				
39	8	P100403	BOLT: HEX, 1/4" X 3/4"				
40	4	P110912	SCREW: CAP, SOCKET HD, 1/4"X1 1/4"				
41	4	P160251	NUT: KLIK, 1/4-20				
42	2	P108508	SCREW: SET, 5/16" X 1/2"				
43	2	P108512	SCREW: SET, 5/16" X 3/4"				
44	2	P100603	BOLT: HEX, 3/8" X 3/4"				
45	5	P100604	BOLT: HEX, 3/8" X 1"				
46	2	P100605	BOLT: HEX, 3/8" X 1 1/4"				
47	2	P100609	BOLT: HEX, 3/8" X 2 1/4"				
48	8	P100806	BOLT: HEX, 1/2" X 1 1/2"				
49	1	P100812	BOLT: HEX, 1/2" X 3"				

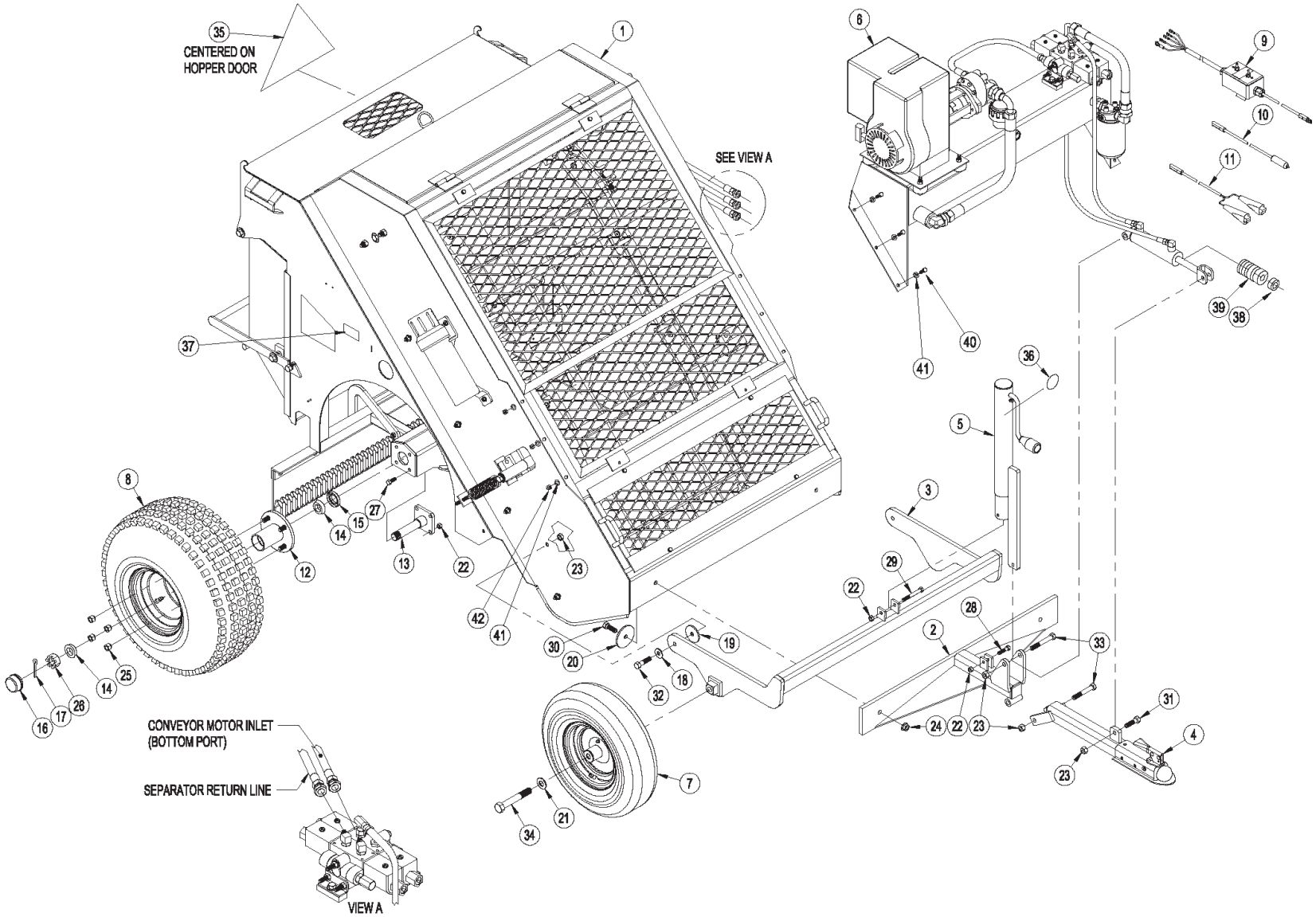

WHEEL AND HITCH ASSEMBLY

WHEEL AND HITCH ASSEMBLY

<u>Item</u>	<u>Qty</u>	<u>Part ID</u>	<u>Description</u>	<u>Item</u>	<u>Qty</u>	<u>Part ID</u>	<u>Description</u>
1	1	M30000	MAIN ASSEMBLY	25	8	P756165	NUT: WHEEL, 1/2"-20
2	1	M30027	800 HITCH TONGUE BASE	26	2	P156402	NUT; SLOTTED HEX, 1"-14
3	1	M30031	GAGE WHEEL MOUNT	27	8	P100605	BOLT: HEX, 3/8" X 1 1/4"
4	1	M30026	1 7/8 BALL HITCH PIVOT TONGUE	28	1	P100606	BOLT: HEX, 3/8" X 1 1/2"
5	1	M30066	HITCH JACK	29	1	P100612	BOLT: HEX, 3/8" X 3"
6	1	M30060	800 HYDRAULIC ASSEMBLY	30	2	P100806	BOLT: HEX, 1/2" X 1 1/2"
7	2	P750001	GAGE WHEEL AND TIRE	31	1	P100807	BOLT: HEX, 1/2" X 1 3/4"
8	2	005360	REAR WHEEL AND TIRE	32	2	P100808	BOLT: HEX, 1/2" X 2"
9	1	M30061	800 SWITCH ASSEMBLY	33	2	P100814	BOLT: HEX, 1/2" X 3 1/2"
10	1	M30091	POWER PIG TAIL	34	2	P101220	BOLT: HEX, 3/4" X 5"
11	1	M6726	CABLE ASSEMBLY	35	1	P977990	DECAL: SMV EMBLEM
12	2	M30133	WHEEL HUB ASSEMBLY	36	1	P977930	DECAL: JACK ROTATION
13	2	M30132	REAR HUB SPINDLE	37	2	P978001	DECAL: CHERRINGTON 800
14	4	P762200	BEARING CONE: 1"	38	1	P128660	COLLAR CYL STOP 3/4
15	2	P756163	GREASE SEAL	39	1	P781001	STROKE CONTROL KIT 7/8
16	2	P756166	DUST CAP	40	6	P100503	BOLT: HEX, 5/16" X 3/4"
17	2	P116256	PIN: COTTER, 5/32" X 1 1/2"	41	6	P850104	WASHER: FLAT, 1/4"
18	2	P850107	WASHER: FLAT, 7/16"	42	6	P155350	NUT: TOP LOCK, 5/16"
19	2	M5462	WASHER: 3/16" X 1/2" ID X 2 1/4" OD	43	1	P297310	GUAGE: TIRE PRESSURE
20	2	M6223	WASHER: 3/16" X 1/2" ID X 3" OD				
21	2	P850812	WASHER: SAE, 3/4"				
22	10	P155450	NUT: TOP LOCK, 3/8"				
23	5	P155850	NUT: TOP LOCK, 1/2"				
24	2	P155851	NUT: SERRATED FLANGE, 1/2"				

CONVEYOR ASSEMBLY

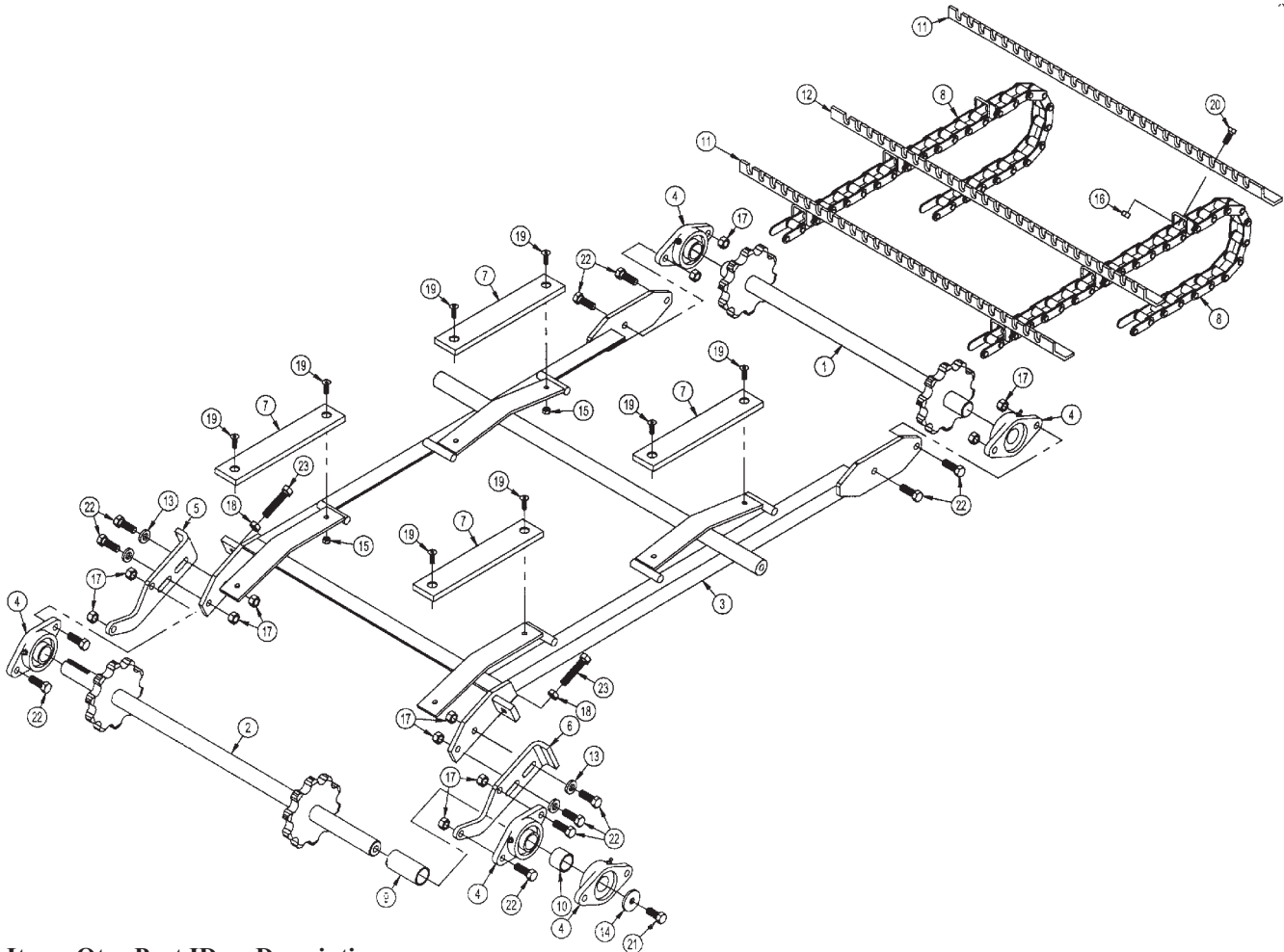

<u>Item</u>	<u>Qty</u>	<u>Part ID</u>	<u>Description</u>
1	1	M30015	FRONT CONVEYOR SHAFT
2	1	M30016	REAR CONVEYOR SHAFT
3	1	M30006	CONVEYOR SUPPORT WELDMENT
4	5	M30073	1-1/4" MODIFIED FLANGE BEARING
5	1	M30007	CONVEYOR ADJUSTMENT BRACKET L
6	1	M30008	CONVEYOR ADJUSTMENT BRACKET R
7	4	M30086	WEAR STRIP *REPLACE WITH 71.000271M
8	2	M30189	CONVEYOR CHAIN WELDMENT
9	1	M30088	3.219 LG CONVEYOR SHAFT SPACER
10	1	M30089	1.125 LG CONVEYOR SHAFT SPACER
11	9	M30092	FLIGHT BLADE RIGHT HAND
12	9	M30093	FLIGHT BLADE LEFT HAND
13	4	P852608	1/2" HARD WASHER
14	1	M5009-5	3/16" X 1/2" X 1-3/4" WASHER
15	8	P155350	5/16" TOP LOCK NUT
16	36	P155450	3/8" TOP LOCK NUT
17	12	P155850	1/2" TOP LOCK NUT
18	2	P157200	1/2" JAM NUT
19	8	P103504	5/16-18 X 1.00 FLAT HD CAP SCREW
20	36	P100604	3/8" X 1" HEX BOLT
21	1	P102805	1/2" X 1-1/4" FINE THD HEX BOLT
22	12	P100806	1/2" X 1-1/2" HEX BOLT
23	2	P098810	1/2" X 2-1/2" FULL THD HEX BOLT

GROOMER & SEPARATOR ASSEMBLY

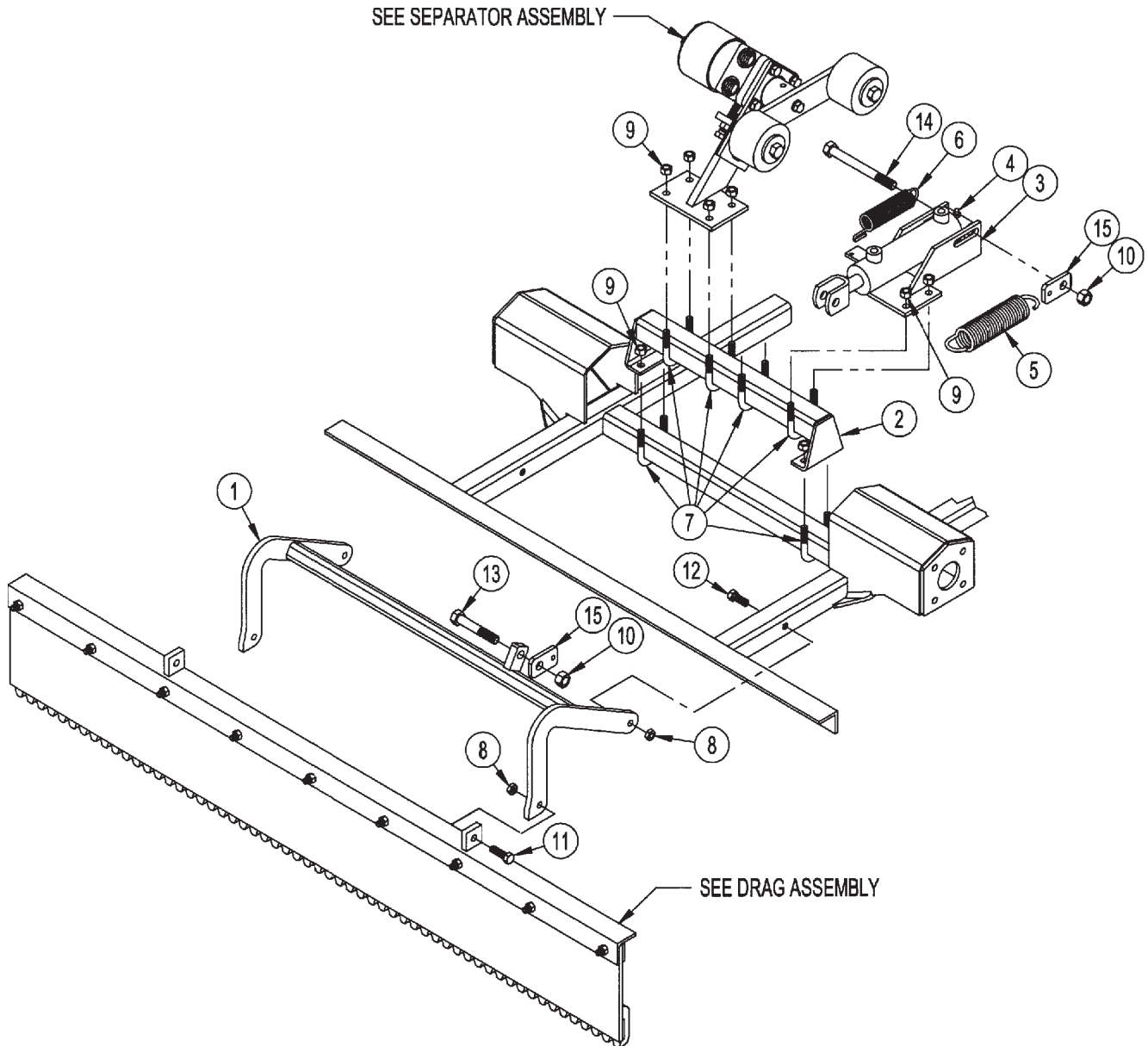

<u>Item</u>	<u>Qty</u>	<u>Part ID</u>	<u>Description</u>
1	1	M30067	LIFT FRAME
2	1	M30110	CONVEYOR RISER BRACKET
3	1	M30023	REAR CYLINDER MOUNT
4	1	P259150	HYDRAULIC CYLINDER 1-1/2" X 4"
		P259151	SEAL KIT
5	1	P601150	EXTENSION SPRING
6	1	P604700	EXTENSION SPRING
7	6	P127204	U-BOLT 3/8" X 1-1/2" X 2-1/4"
8	4	P155400	3/8" JAM NUT
9	12	P155450	3/8" TOP LOCK NUT
10	2	P155850	1/2" TOP LOCK NUT
11	2	P100605	3/8" X 1-1/4" HEX BOLT
12	2	P100609	3/8" X 2-1/4" HEX BOLT
13	1	P100812	1/2" X 3" HEX BOLT
14	1	P100820	1/2" X 5" HEX BOLT

GROOMER BAR ASSEMBLY

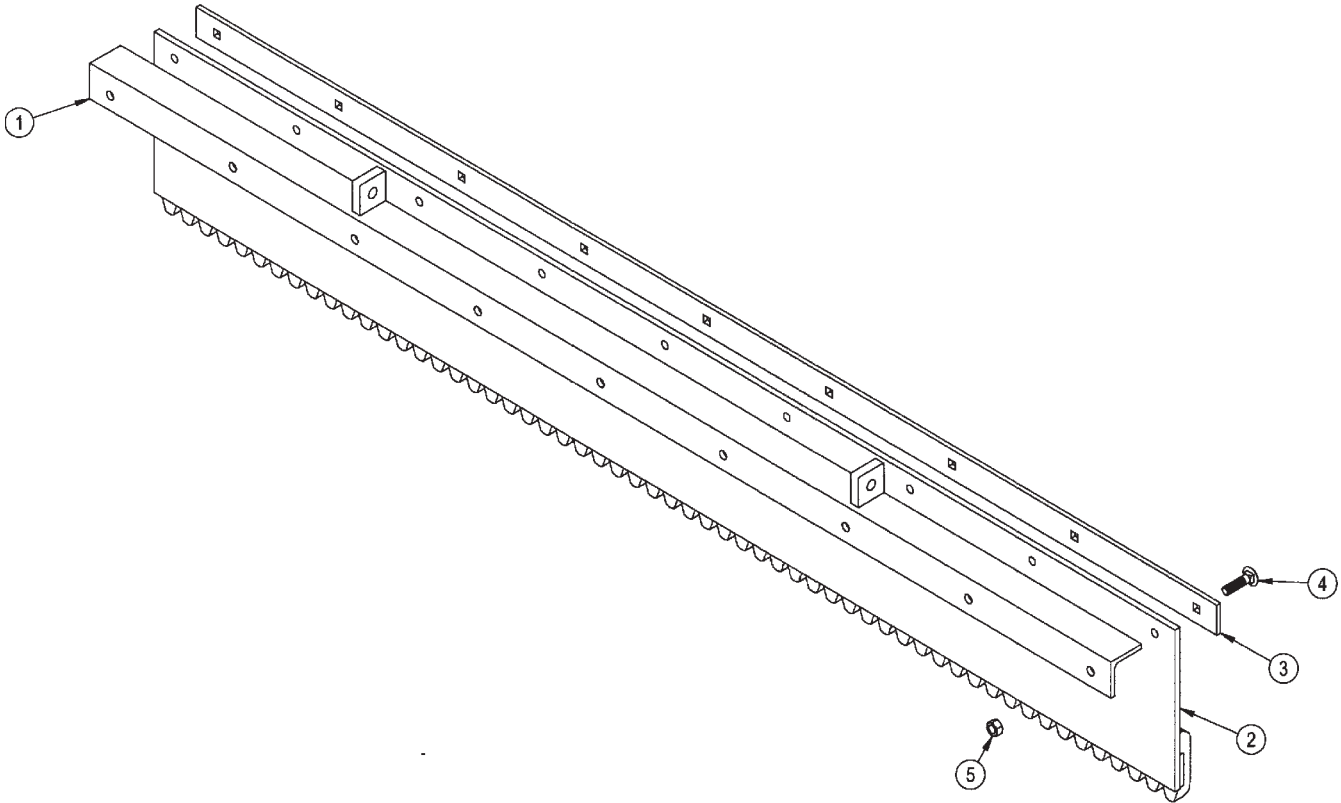

<u>Item</u>	<u>Qty</u>	<u>Part ID</u>	<u>Description</u>
		M30182	GROOMER BAR ASSEMBLY (Includes Items 1-5)
1	1	M30181	DRAG COMB MOUNT
2	1	M30183	SNOW COMB
3	1	M30180	DRAG COMB STRAP
4	9	P104505	5/16" X 1-1/4" CARRIAGE BOLT
5	9	P155350	5/16" TOP LOCK NUT

SEPARATOR ASSEMBLY

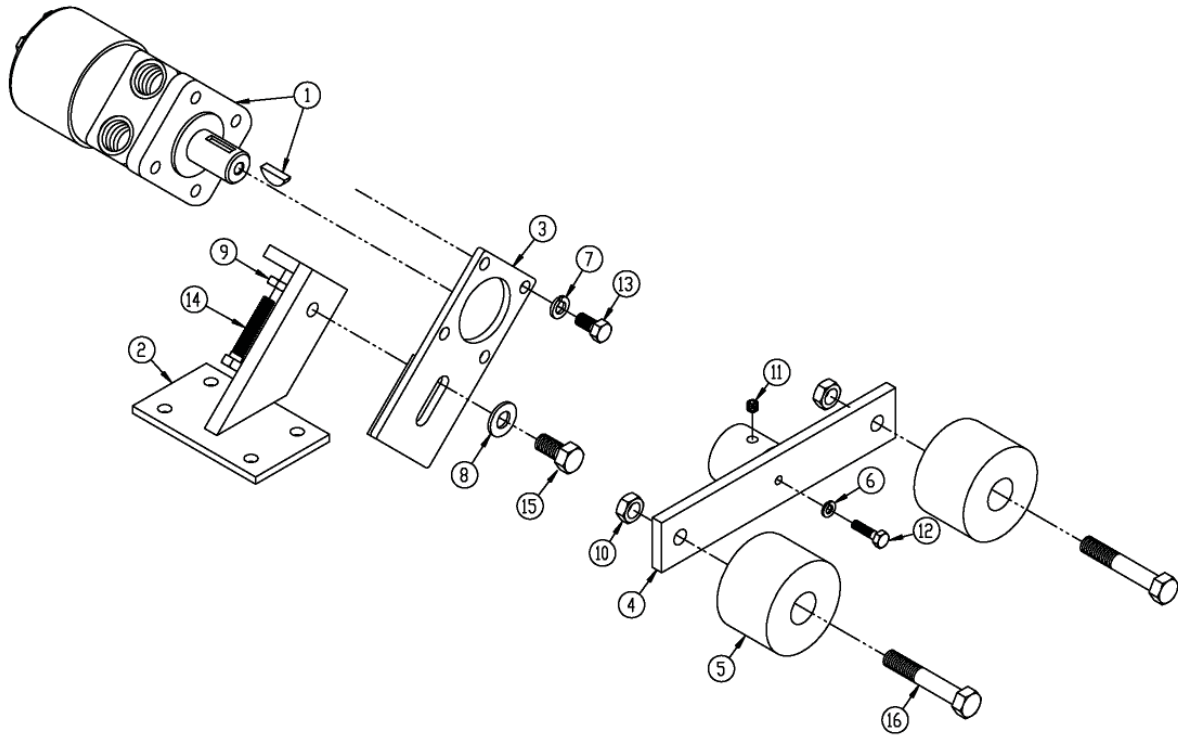

ITEM	QTY	PART#	DESCRIPTION
1	1	P350500	PARKER MOTOR TC0130FS100AAA
		P350501	SEAL KIT
2	1	M30018	SEPARATOR MOUNT
3	1	M30019	SEPARATOR MOTOR MOUNT
4	1	M30020	SEPARATOR ARM
5	2	P761100	SNUGULATOR 2500BD1X
6	1	P851104	1/4" LOCK WASHER
7	4	P851106	3/8" LOCK WASHER
8	1	P852608	1/2" HARD WASHER
9	1	P155400	3/8" JAM NUT
10	2	P157200	1/2" JAM NUT
11	1	P108505	5/16" X 5/16" SET SCREW
12	1	P100404	1/4" X 1" HEX BOLT
13	4	P100603	3/8" X 3/4" HEX BOLT
14	1	P098608	3/8" X 2" FULL THD HEX BOLT
15	1	P100804	1/2" X 1" HEX BOLT
16	2	P100812	1/2" X 3" HEX BOLT

800 HYDRAULIC ASSEMBLY

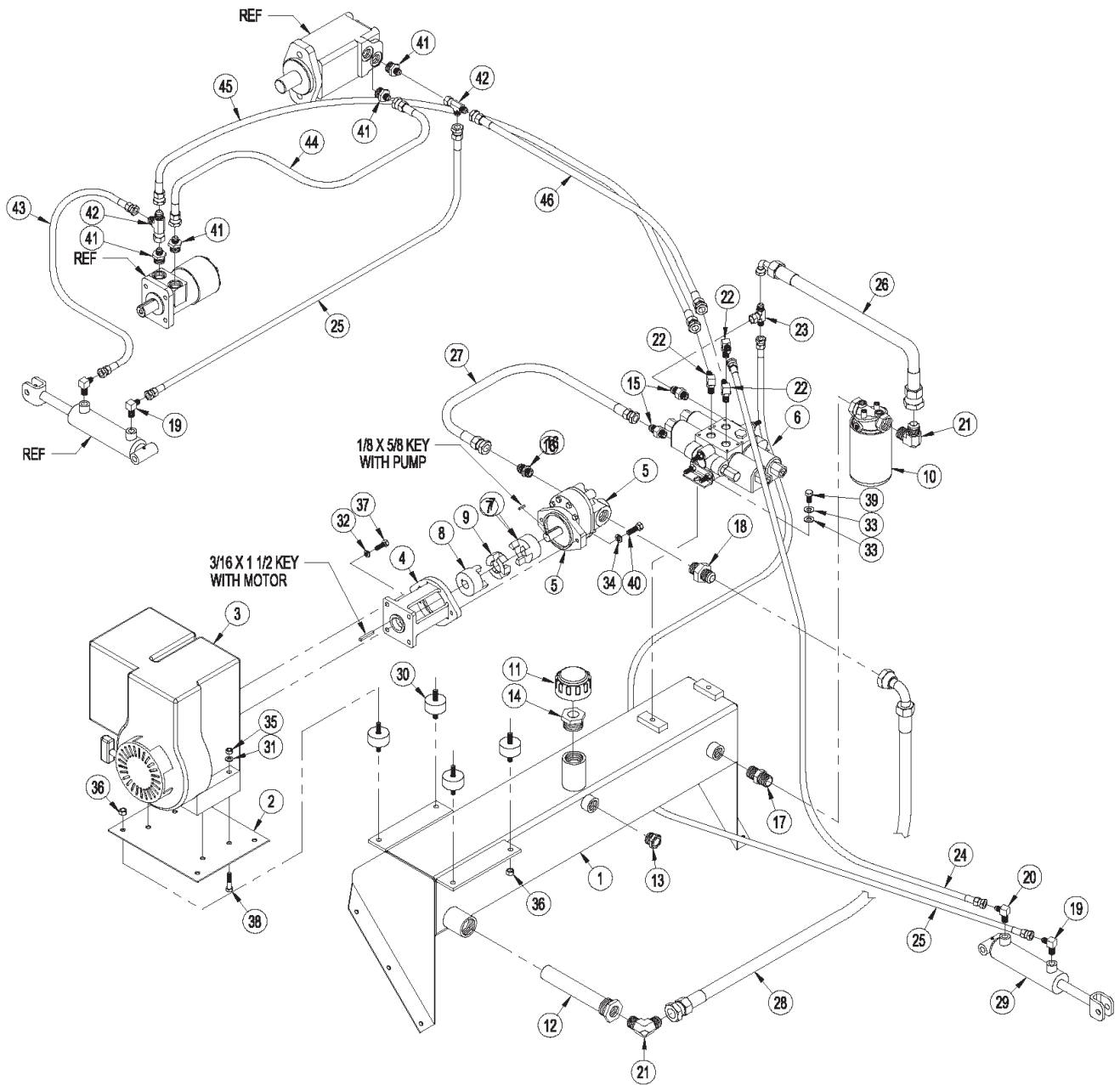

800 HYDRAULIC ASSEMBLY

<u>Item</u>	<u>Qty</u>	<u>Part ID</u>	<u>Description</u>	<u>Item</u>	<u>Qty</u>	<u>Part ID</u>	<u>Description</u>
1	1	M30062	HYDRAULIC RESERVOIR	30	4	P133030	RUBBER MOUNT
2	1	M30059	ENGINE MOUNT PLATE	31	4	P850104	WASHER: FLAT, 1/4"
3	1	P370100	6.5 HORSE POWER HONDA ENGINE	32	4	P851105	WASHER: LOCK, 5/16"
4	1	P133210	PUMP MOUNT	33	4	P850105	WASHER: FLAT, 5/16"
5	1	P555350	GEAR PUMP	34	2	P851106	WASHER: LOCK, 3/8"
6	1	P293100	VALVE: SOLENOID 2 SPOOL	35	4	P155350	NUT: TOP LOCK, 5/16
7	1	P360100	COUPLING: DRIVE, 5/8"	36	8	P155450	NUT: TOP LOCK, 3/8"
8	1	P360105	COUPLING: DRIVE, 3/4"	37	4	P102504	BOLT: HEX, FINE, 5/16" X 1"
9	1	P360110	COUPLING INSERT	38	4	P100506	BOLT: HEX, 5/16" X 1 1/2
10	1	P610200	FILTER: FLOW EZY	39	2	P100603	BOLT: HEX, 3/8" X 3/4"
		P371850	FILTER ELEMENT	40	2	P100605	BOLT: HEX, 3/8" X 1 1/4"
11	1	P610100	FILLER CAP	41	4	P276215	ADAPTER: 10MB-6MJ
12	1	P610300	TANK STRAINER	42	2	P265550	TEE: 6FJX-6MJ-6MJ
13	1	P610400	LEVEL SIGHT PLUG	43	1	P244160	HOSE: 1/4", 4FJX-6FJX 16"
14	1	P267390	REDUCER BUSHING: 20MP-12FP	44	1	P248042	HOSE: 3/8", 6FJX-6FJX 42"
15	2	P276101	ADAPTER: 6MB-6MJ	45	1	P248060	HOSE: 3/8", 6FJX-6FJX 60"
16	1	P276200	ADAPTER: 10MB-10MJ	46	1	P248036	HOSE: 3/8", 6FJX-6FJX 36"
17	1	P267270	NIPPLE: HEX, 3/4, 12MP-12MP				
18	1	P276450	ADAPTER: 12MB-12MJ				
19	3	P261410	ELBOW: 4MP-4MJ90°				
20	1	M30063	ELBOW WITH ORIFACE				
21	2	P276490	ELBOW: 12MP-12MJ90°				
22	3	P261350	ELBOW: 6MB-6MJ90°				
23	1	P265450	TEE: 6MJ-6MJ-6FJX				
24	1	P245045	HOSE: 1/4", 4FJX-6FJX 45"				
25	2	P245050	HOSE: 1/4", 4FJX-6FJX 50"				
26	1	P250719	HOSE: 1/2", 12FJX-6FJX90° 19"				
27	1	P251128	HOSE: 1/2", 10FJX-6FJX 28"				
28	1	P255971	SUCTION HOSE: 3/4", 12FJX-12FJX90°				
29	1	P259150	CYLINDER: HYDRAULIC, 1 1/2 X 4"				
		P259151	SEAL KIT				

OPTIONAL COLLECTION BAG ASSEMBLY

A collection bag assembly is available as an add-on option to your Model 800.

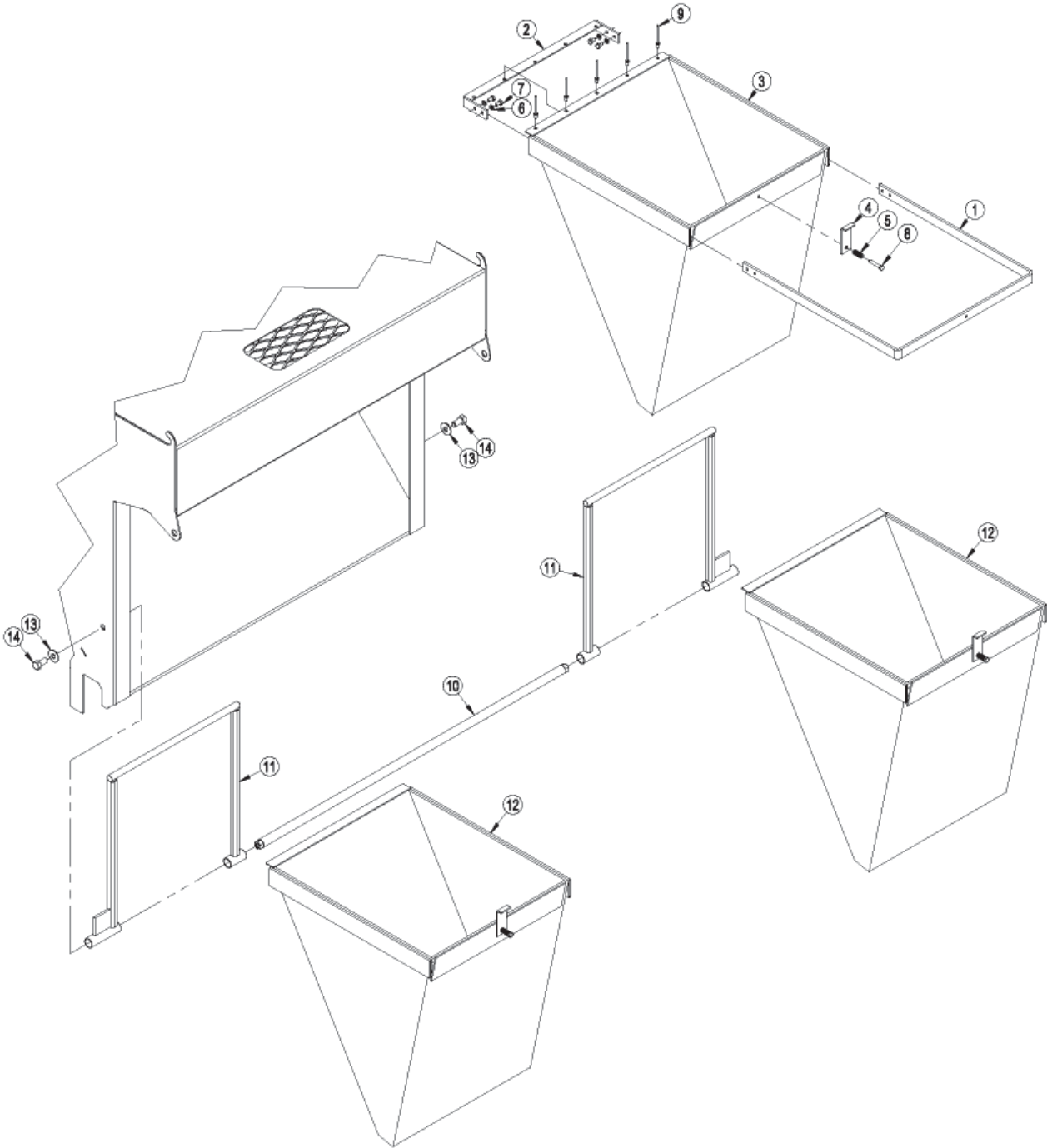

OPTIONAL COLLECTION BAG ASSEMBLY

<u>Item</u>	<u>Qty</u>	<u>Part ID</u>	<u>Description</u>
1	1	M30157	BAGGER TOP HOLDER
2	1	M30158	TOP HOLDER BRACKET
3	1	M30159	COLLECTION BAG
4	1	M30161	BAG LATCH
5	1	P601050	SPRING: COMPRESSION, .48 OD X 1"
6	4	P851104	WASHER: LOCK, 1/4"
7	4	P100402	BOLT: HEX, 1/4" X 1/2"
8	1	P100406	BOLT: HEX, 1/4" X 1 1/2"
9	5	P126272	POP RIVET: LARGE FLANGE, 1/8" X 3/8"
10	1	M30156	BAGGER CROSS BAR
11	2	M30155	BAGGER MOUNT
12	2	M30162	COLLECTION BAG ASSEMBLY
13	2	P850107	WASHER: FLAT, 7/16"
14	2	P100804	BOLT: HEX, 1/2" X 1"

800 WIRING DIAGRAM

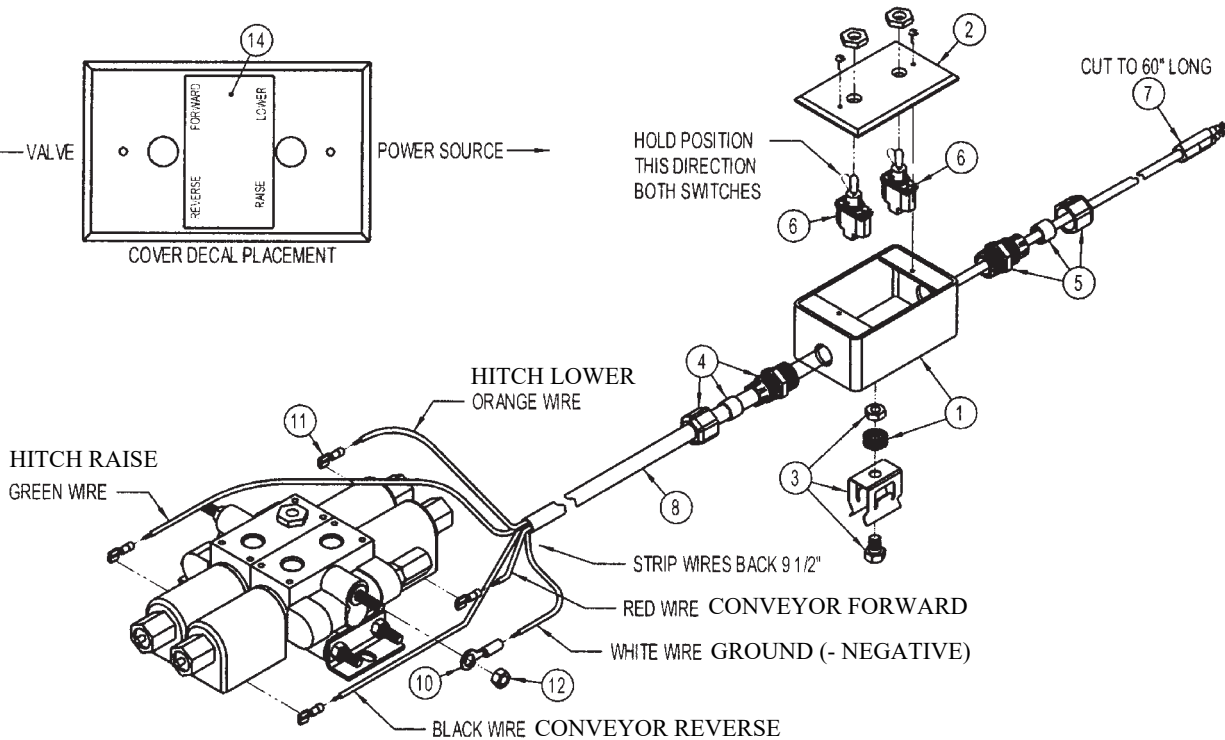
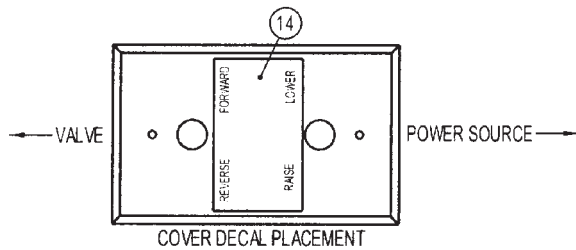
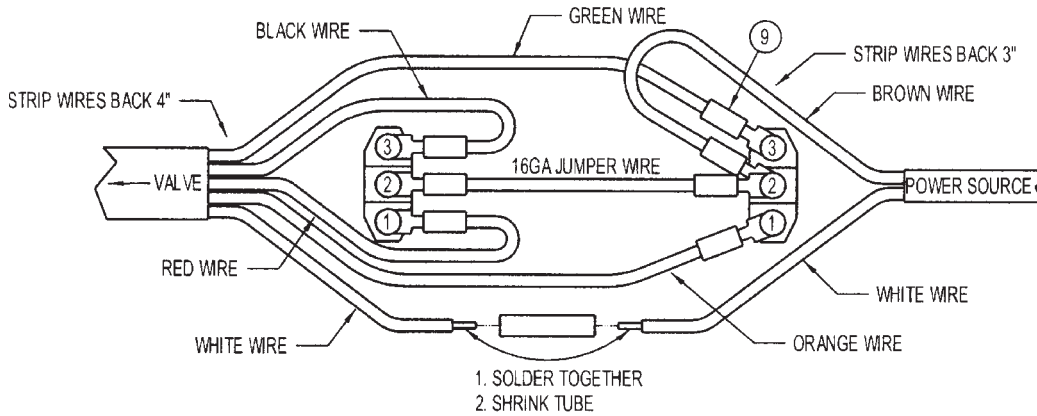

Item	Qty	Part ID	Description
1	1	M30064	CONTROL BOX
2	1	M30065	CONTROL BOX COVER
3	1	P296200	CONTROL BOX CLAMP
4	1	P296700	CABLE GRIP LARGE
5	1	P296600	CABLE GRIP SMALL
6	2	P296900	TOGGLE SWITCH (MOM-OFF-ON)
7	1	P295016	MALE BETTS CABLE 8 FT
8	1	R99000080	16GA 5 CONDUCTOR CABLE 156"
9	7	P295045	#6 RING TERMINAL
10	1	P295069	5/16" RING TERMINAL
11	4	P295070	1/4" FEMALE SPADE TERMINAL
12	1	REF	5/16" HEX NUT
13	1	R99000015	16 GA JUMPER WIRE 3"
14	1	P977985	COVER DECAL