

HITCH, LEVELING BLADE AND RESERVOIR REFERENCE

<u>ITEM</u>	<u>QTY</u>	<u>PART NUMBER</u>	<u>DESCRIPTION</u>
1	2	470123	BUSHING: 1" X 5/8" X 2-5/8
2	1	470132	HITCH: BOLT ON PINTLE
3	1	470153	OIL TANK: 4700, 18 GAL
4	1	470229	ADAPTER: PINTLE HOOK, 3 POINT
5	1	470314	BLADE: LEVELING 4700
6	1	005123	CHAIN: TORQUE ARM
7	1	005231	TORQUE ARM: EATON PTO
8	1	005313	HOSE LOOP ASSY, SLIDER
9	1	P120410	PIN: CAT 2 TOP LINK
10	2	P120850	PIN: CLEVIS, 1"
11	4	P133035	SPACER: RUBBER, 2" X 1"
12	1	P135004	LINK: QUICK, 1/4
13	1	P135005	LINK: QUICK, 5/16"
14	1	P135102	BOLT: 3/8-16 X 1-1/4 FORGED EYE
15*	1	P259380	CYLINDER: 1.5B X 6S W/CAV CH
16	1	P297185	GAUGE: IND VMF2E.0
17	1	P292200	VALVE ASSY: 6 BANK 04-0699A-ASY
18	1	P297220	GAUGE: OIL SIGHT
19	1	P371920	FILTER: TANK TOP
20	1	P371921	GASKET: TANK TOP FILTER
21	1	P371925	ELEMENT: FILTER
22	1	P466100	PINTLE HOOK: 15 TON
23	1	P556600	PUMP: EATON PTO #77022-LAH
24	2	P620200	FITTING: GREASE, 1/4-28 STR
25	3	P622603	PIN: LYNCH, 7/16 X 1-1/4
26	1	P780100	STRAINER: HYD OIL

* #15 CYLINDER USES PILOT OPERATED LOAD CHECK QTY 1 PER CYLINDER
71.P294250 (NOT INCLUDED WITH CYLINDER)



HITCH, LEVELING BLADE, AND RESERVOIR DIAGRAM

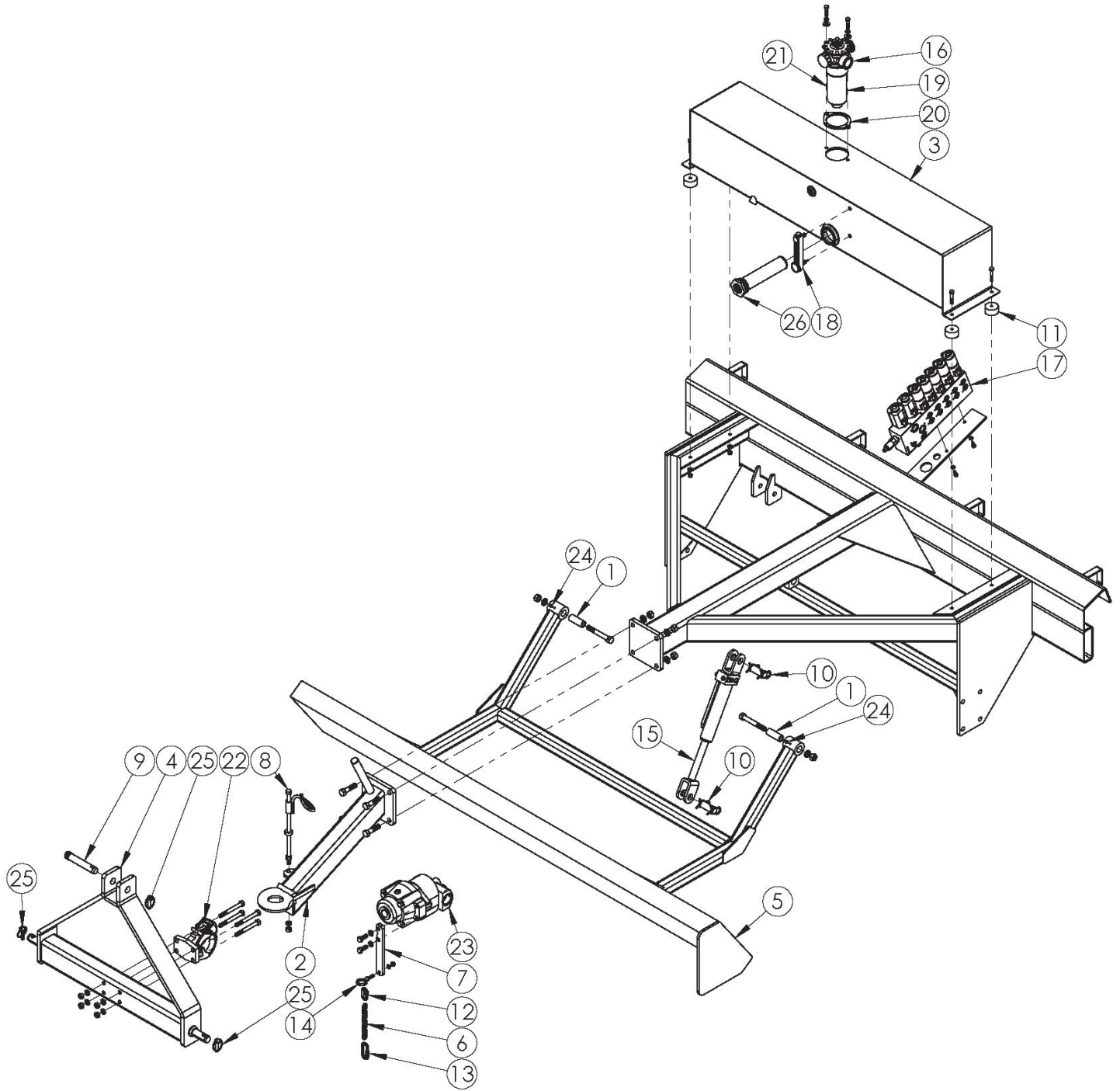

PTO PUMP

PLANETARY GEARBOX DRIVE / HYDRAULIC GEAR PUMP

- 1) 71.P556600 COMPLETE PUMP ASSEMBLY (PLANETARY GEARBOX / HYDRAULIC GEAR PUMP FULLY ASSEMBLED)
- 2) 71.P556610 HYDRAULIC GEAR PUMP (GEAR PUMP SECTION ONLY)
- 3) 71.P556611 HYDRAULIC GEAR PUMP SEAL KIT
- 4) 71.V16253-34 PTO / PLANETARY GEARBOX INPUT SHAFT SEAL
- 5) 71.V160.15 O RING

HYDRAULIC GEAR PUMP SECTION

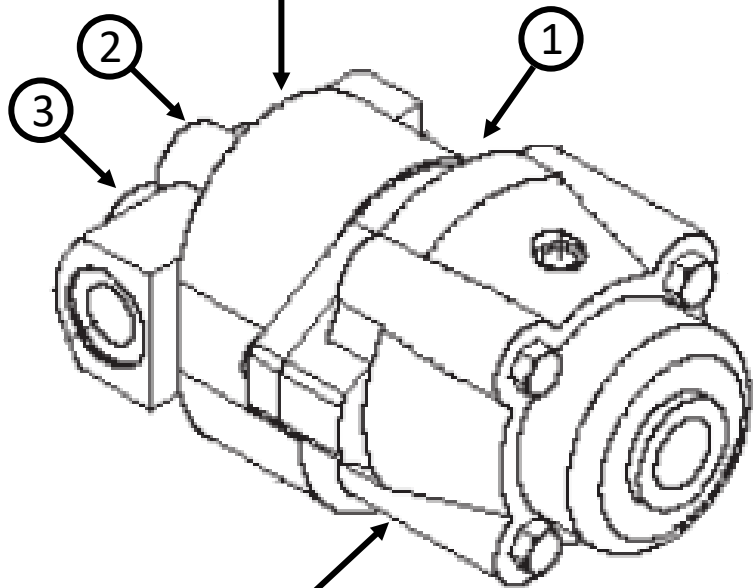

PLANETARY GEARBOX DRIVE SECTION

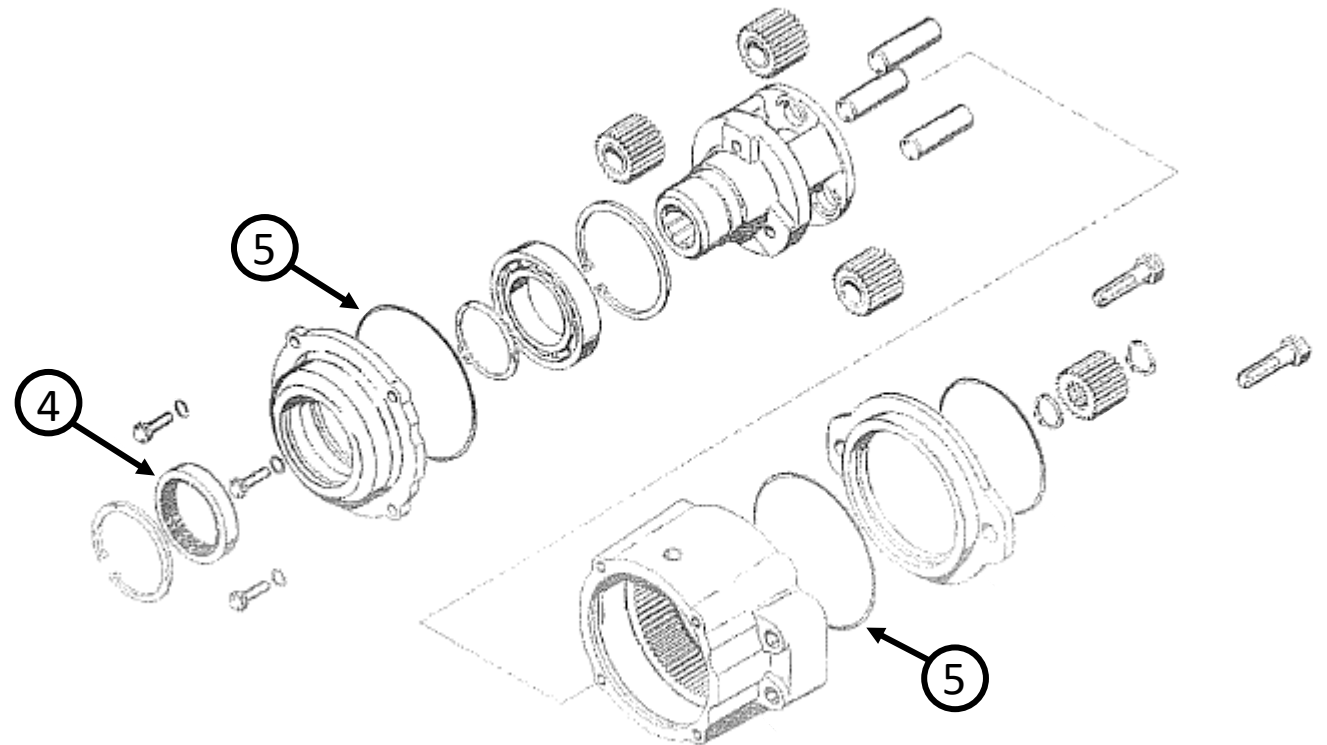

PLANETARY GEARBOX DRIVE EXPLODED VIEW

HANGER FRAME PARTS REFERENCE

ITEM	QTY	PART NUMBER	DESCRIPTION
1	1	470034	CONVEYOR SUPPORT: 4700 (RA)
2	2	470071	BRACKET: FRONT SHAFT ADJ
3	1	470074	PITMAN ARM: RIGHT
4	1	470075	PITMAN ARM: LEFT
5	1	470077	PITMAN SHAFT ASSEMBLY
6	1	470080	FLIGHT ANGLE: 35°
7	2	470123	BUSHING: 1" X 5/8" X 2-5/8
8	2	470130	PUCK: FLIGHT
9	2	470159	BRACKET: COMPRESSION LIMITER
10	2	470160	PAD: WEAR, 2-1/4 X 5
11	1	470170	BLADE: FLIGHT, 4700
12	1	470216	HANGER FRAME
13	2	470231	PAD: WEAR, 2-1/4 X 8
14	2	470309	PIN: DIGGER CYLINDER
15	1	470319	SHAFT: 4700 FRONT CONV
16	1	000068M	KEY: 3/8 X 1-7/16
17	2	000271M	WEAR STRIP: CONVEYOR
18	2	P003175	BEARING: IPTCI UCFCX09-28 FLANGE
19	2	P116308	PIN: COTTER, 3/16" X 2"
20	2	P120850	PIN: CLEVIS, 1"
21	2	P126840	BUSHING: RUBBER, J6424-1
22	2	P133075	MOUNT: ISOLATOR, J-5425-275
23	2	P133320	BUMPER: SHOCK
24*	2	P259305	CYLINDER: 2B X 10S W/CAV CH
25	1	P272910	COUPLING ASSEMBLY, 38/45
26	1	P272911	INSERT: SPIDER, #38 SERIES
27	1	P353400	MOTOR: C/L 158-1537 4.0 CID
28	4	P620200	FITTING: GREASE, 1/4-28 STR
29	4	P632500	CHAIN: #620 CONV 31 CLT
30	16	P761100	SNUGULATOR: 2500BD1X
31	2	P781000	STROKE CONT SET

* #24 P259305 HYD CYL USES PILOT OPERATED LOAD CHECK QTY 1 PER CYLINDER
71.P294250 (NOT INCLUDED WITH CYLINDER)



HANGER FRAME DIAGRAM

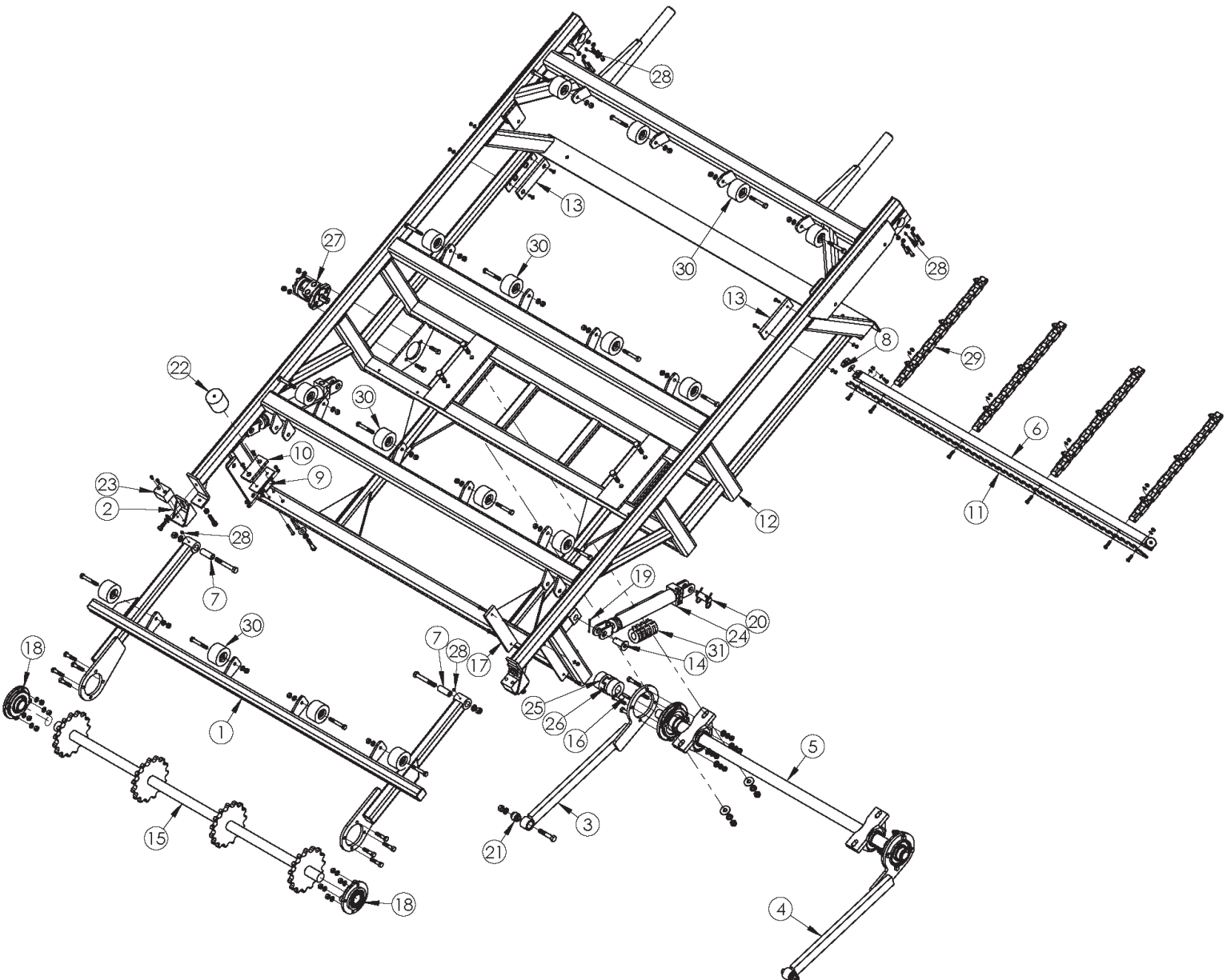

SCREEN FRAME PARTS REFERENCE

<u>ITEM</u>	<u>QTY</u>	<u>PART NUMBER</u>	<u>DESCRIPTION</u>
1	2	470069	GLIDE RAIL: 35°
2	1	470099	SCREEN: 3/4"
3	2	470160	PAD: WEAR, 2-1/4 X 5
4*	1	470173	EDGE: CUTTING, 4700
5	1	470207	FRAME: SCREEN, 4700
6	1	470208	BAR: SCREEN TENSION
7	2	470217	ROCKER ARM: 14"
8	4	P126820	BUSHING: RUBBER, J5385-32

*NOT SHOWN CUTTING EDGE MOUNTING HARDWARE

QTY 4 71.P100605 3/8-16 X 1-1/4 GR 5 HEX BOLT

QTY 4 71.P851106 3/8 LOCK WASHER

QTY 4 71.P150600 3/8-16 GR 5 HEX NUT

SCREEN FRAME DIAGRAM

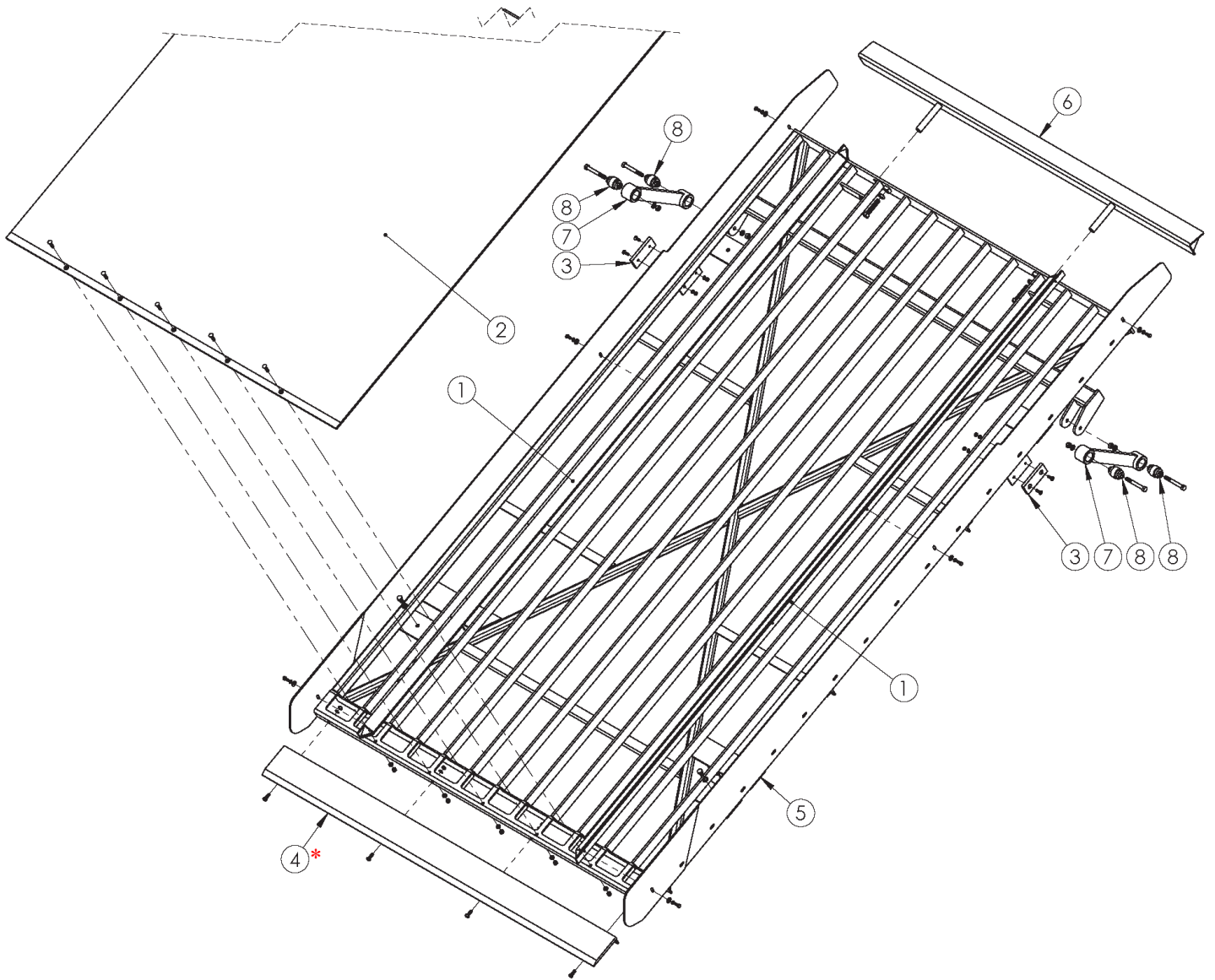

HOPPER, HOPPER LIFT AND GROOMER REFERENCE

<u>ITEM</u>	<u>QTY</u>	<u>PART NUMBER</u>	<u>DESCRIPTION</u>
1	1	470044	SHAFT: 4700 CONV
2	1	470064	HOPPER BODY
3	1	470081	SHAFT MOUNT: REAR
4	1	470185	SHAFT: ROLLOVER CRANK, 4700
5	1	470186	BOOM: 4700
6	1	470187	HOPPER: REAR SHAFT ASSEMBLY
7	2	470192	PLATE: HOPPER SPROCKET
8	1	470196	BACK PANEL ASSEMBLY: HOPPER
9	2	470310	CHAIN: HOPPER CRANK ASSEMBLY
10	2	470311	CHAIN: HOPPER DRIVEN ASSEMBLY
11	1	002845	KEY: 3/8 X 1-7/8
12	2	P003175	BEARING: FLANGE IPTCI UCFCX09-28
13	1	004229	PIPE: SPRING MOUNT, BC
14	1	004862	BAR: GROOMER, 5000
15	1	004864	BRACKET: LIFT, 5000 GROOMER
16	2	004883	PAD: WEAR, 5000 GROOMER
17	1	005337	GROOMER COMB: CENTER
18	2	005338	GROOMER COMB: OUTSIDE
19	1	005339	BRACKET: GROOMER COMB, CENTER
20	2	005340	BRACKET: GROOMER COMB, OUTSIDE
21	1	000358M	STOP: RUBBER
22	4	P116308	PIN: 3/16" X 2" COTTER
23	6	P120850	PIN: CLEVIS, 1"
24	2	P121200	PIN: BENT HITCH, 3/4" X 3-1/2"
25	8	P128903	CLAMP: INSULATED, 3/4"
26*	1	P259160	CYLINDER: 1-1/2B X 4S W/CAV CH
27*	2	P259330	CYLINDER: 2B X 8S W/CAV CH
28*	2	P259360	CYLINDER: 2.5B X 28S W/CAV CH
29	1	P272970	COUPLER ASSEMBLY: 42/55
30	1	P272971	INSERT: SPIDER, #42 SERIES
31	1	P293910	VALVE: RELIEF, HF #07-0287A
32	1	P353500	MOTOR: C/L 104-1206 18.7 CID
33	2	P605700	SPRING: DIE 5"
34	8	P620200	FITTING: GREASE, 1/4-28 STR

* #27 HYDRAULIC CYLINDERS USE A PILOT OPERATED LOAD CHECK QTY 1 PER CYLINDER
71.P294250 (NOT INCLUDED WITH CYLINDER)

#28 P259360 HYD CYL USES PILOT OPERATED COUNTER BALANCE LOAD CHECK QTY 1 PER CYL
71.P294260 (NOT INCLUDED WITH CYLINDER)

HOPPER, HOPPER LIFT AND GROOMER DIAGRAM

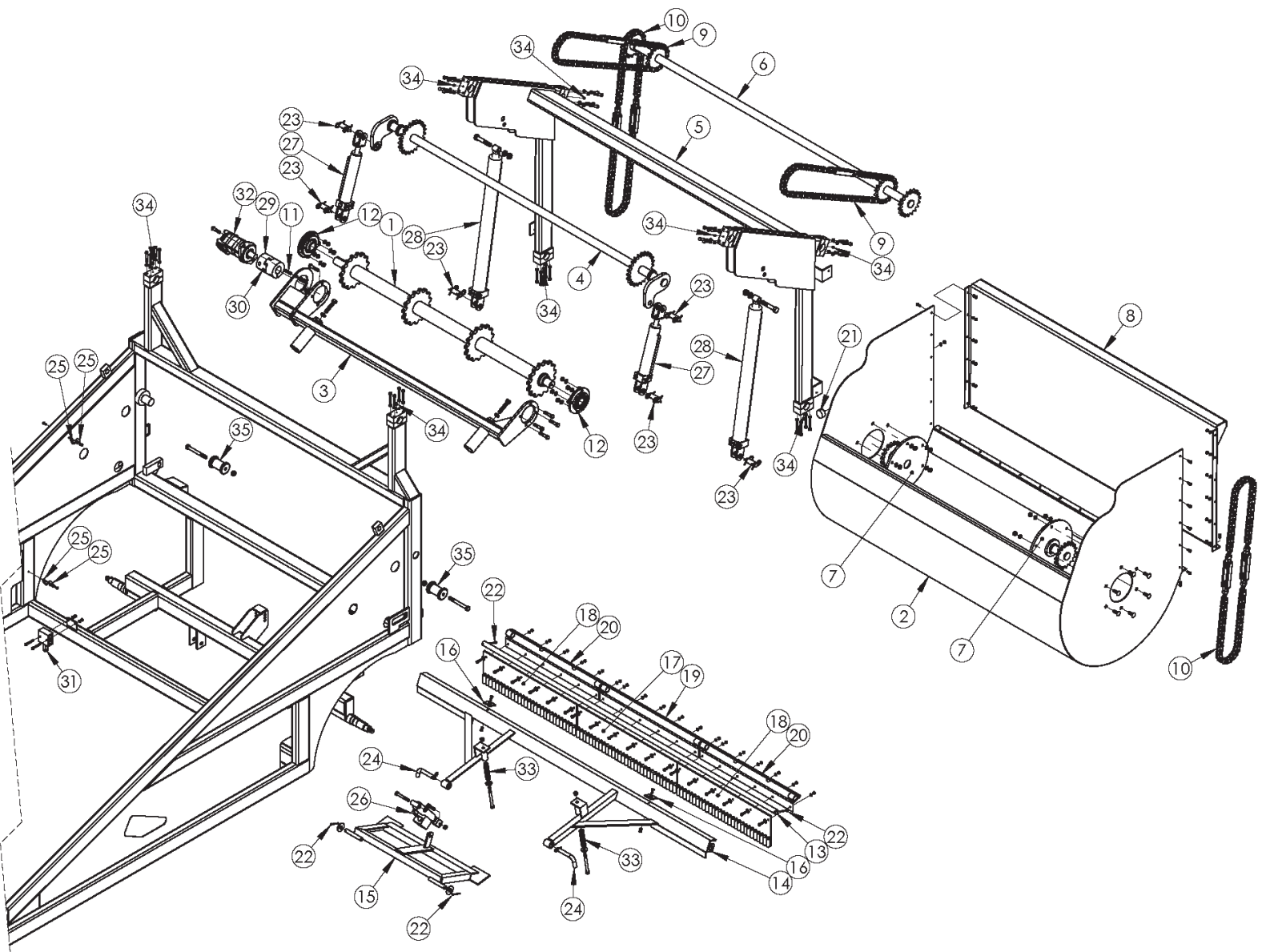

WHEELS AND SHIELDS PARTS REFERENCE

<u>ITEM</u>	<u>QTY</u>	<u>PART NUMBER</u>	<u>DESCRIPTION</u>
1	2	470119	WHL ASSY: 16.5 X 16.1
		P763450	TIRE: 16.5L X 16.1 SL
		P750800	RIM: PIONEER #106987
2	2	470152	WHEEL ASSY: 26 X 12-12
		P763300	TIRE: 26 X 12-12 TURF TRAC
		P750300	RIM: 12 X 10.50
3	1	470157	BRACKET: COOLER
4	2	470193	GUARD: HOPPER DRIVE CHAIN
5	2	470223	SHIELD: PITMAN BEARING
6	1	470225	SHIELD: VALVE COVER
7	1	470227	FRAME: CONVEYOR COVER
8	2	470228	SHIELD: CONVEYOR
9	1	470230	SHIELD: CONVEYOR RF
10	2	470305	HOIST: SAFETY LOCK
11	2	470316	SPACER: RUBBER, PROP BAR
12	2	470318	PIN: SAFETY, PROP BAR
13	2	005101	HUB ASSEMBLY: 8 BOLT
14	2	005201	AXLE: GAUGE WHEEL
15 *	1	P117300	COOLER: HYD OIL AKG DC16-12
16	12	P160251	NUT: 1/4-20 KLIK .08-.14
17	2	P622603	PIN: LINCH, 7/16 X 1-1/4
18	2	P764300	HUB ASSEMBLY: 6 BOLT
19	1	P999000	BOX: OWNERS MANUAL

*NOT SHOWN 71.P117310 COOLING FAN ONLY



WHEELS AND SHIELDS DIAGRAM

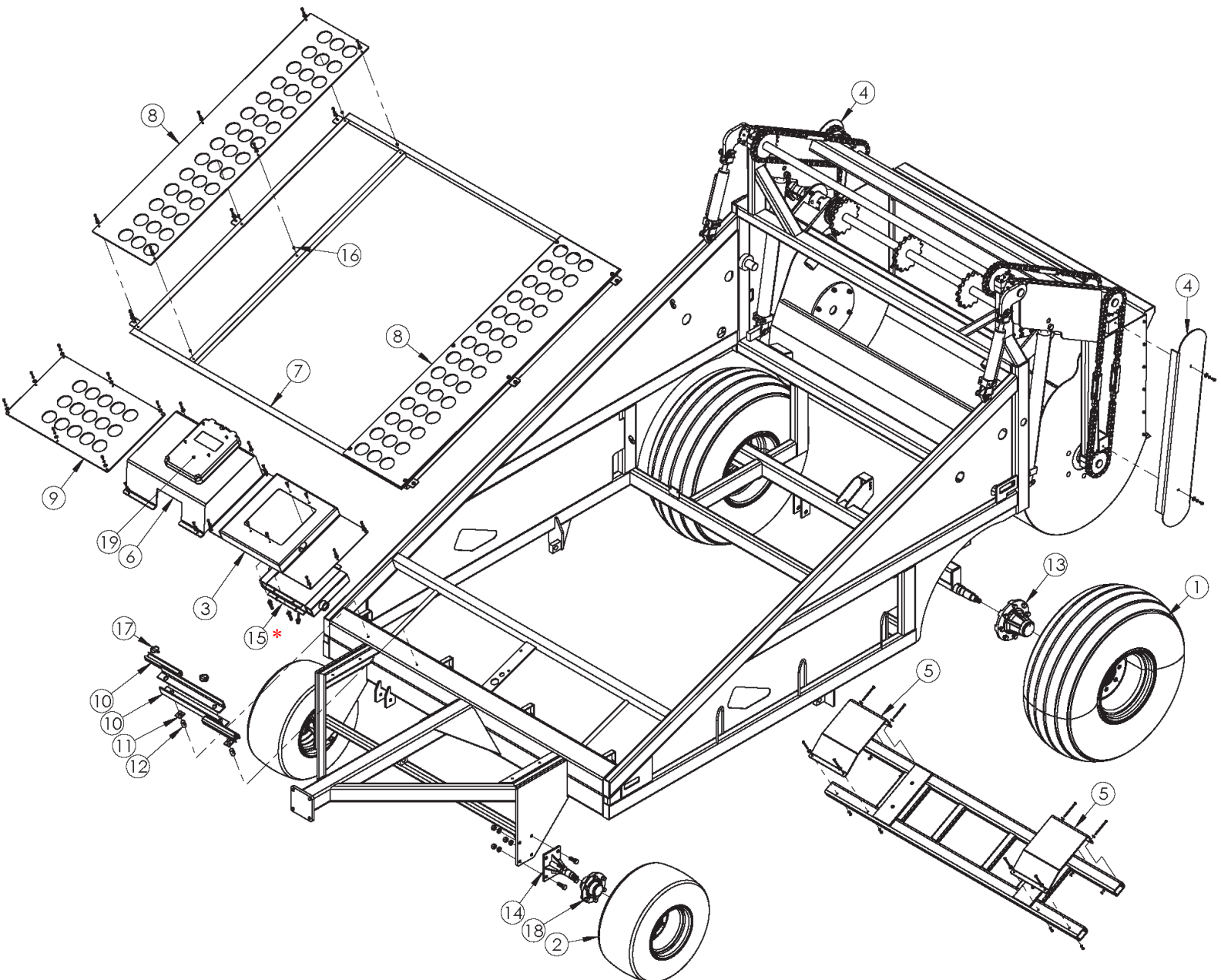

HYDRAULICS LEGEND

- A. 20MJ-20MP, P289993, 20MJ-20MB
- B. 6MJ-6MB90, P283099, 6MJ-6MP
- C. 10MJ-12MB, P285918, 10MJ-10MB90
- D. 12MJ-10MB, P286940, 12MJ-16MB
- E. 12MJ-16MB, P286959, 12MJ-16MB90
- F. 10MJ-10MB, P285136, 10MJ-10MB
- G. 10MJ-10MB, P285990, 10MJ-10MB45
- H. 10MJ-10MB45, P285990, 10MJ-10MB
- I. 10MJ-10MB, P285030, 10MJ-10MB90
- J. 10MJ-10MB, P285939, 10MJ-10MB45
- K. 4MJ-4MB90, P282437, 4MJ-6MB
- L. 4MJ-6MB, P282946, 4MJ-6MB90
- M. 4MJ-6MB .035R, P282946, 4MJ-6MB90
- N. 6MJ-6MB45 .100R, P283158, 6MJ-6MB90
- O. 6MJ-6MB45, P283158, 6MJ-6MB90
- P. 6MJ-6MB45 .100R, P283158, 6MJ-6MB90
- Q. 6MJ-6MB45, P283158, 6MJ-6MB90
- R. 6MJ-6MB45, P283209, 6MJ-6MB90
- S. 6MJ-6MB45 .100R, P283209, 6MJ-6MB90
- T. 6MJ-6MB45, P283209, 6MJ-6MB90
- U. 6MJ-6MB45 .100R, P283209, 6MJ-6MB90
- V. 6MJ-6MB45, P283184, 6MJ-6MB90
- W. 6MJ-6MB45 .045R, P283184, 6MJ-6MB90
- X. 6MJ-6MB45, P283184, 6MJ-6MB90
- Y. 6MJ-6MB45 .045R, P283184, 6MJ-6MB90
- Z. 4MJ-6MB45 .035R, P282201, 4MJ-4MB90
- AA. 4MJ-6MB45, P282201, 4MJ-4MB90
- GP. PD361 NIPPLE

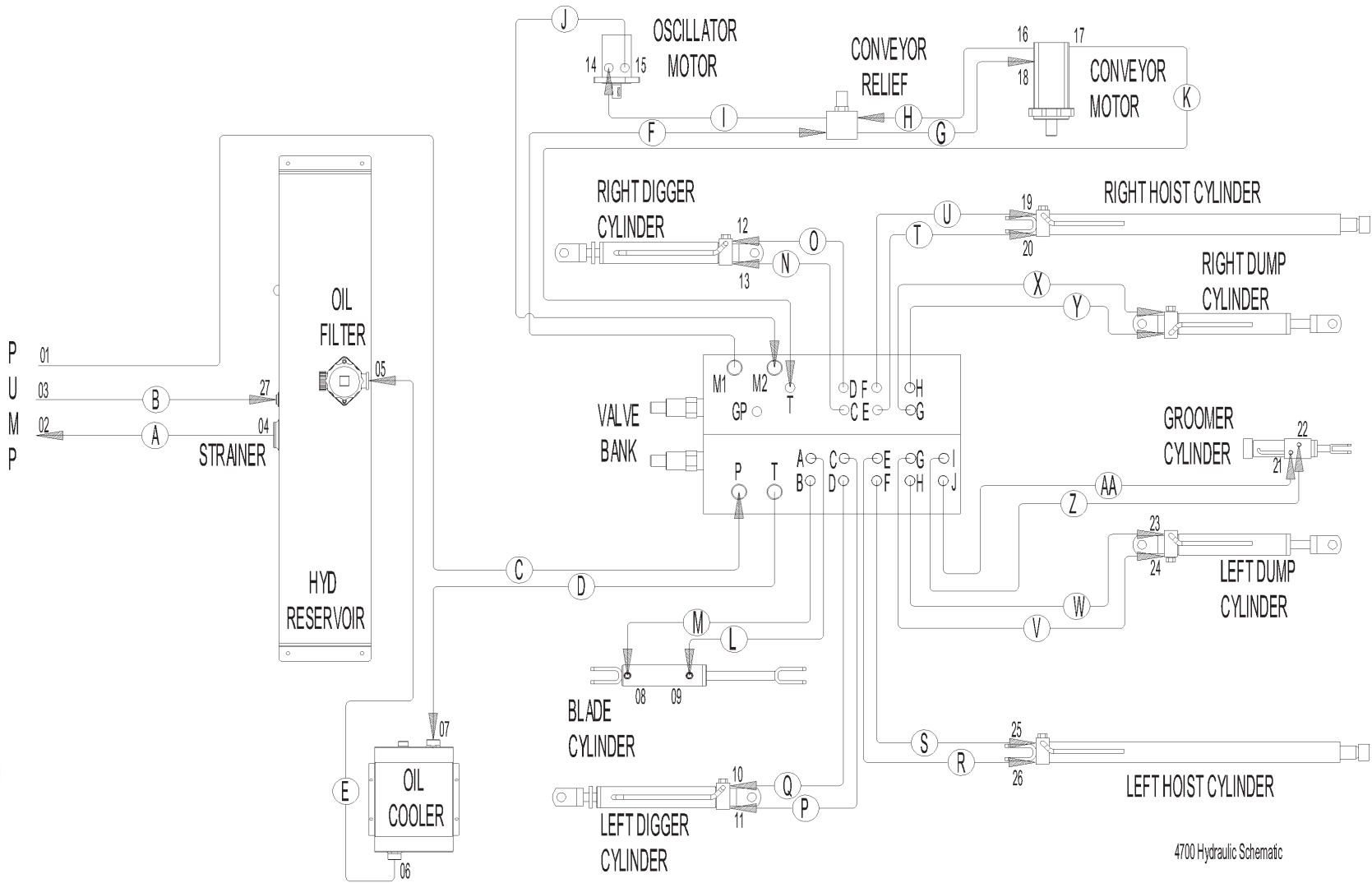

4700 Hydraulic Schematic

HYDRAULICS SCHEMATIC

ELECTRICAL LEGEND

The EA-1067 control box has six toggle switches. It includes auto up/down function for the Groomer and when the forward Conveyer is turned on the fan and hour meter will be activated.

<u>WIRE COLOR</u>	<u>FUNCTION</u>	<u>PIN</u>
Green	Fan Power (1 of 2)	A
White/Red	Fan Power (2 of 2)	R
Blue	Conveyer Forward	C
White	Conveyer Reverse	E
White/Black	Digger Raise	F
Red	Digger Lower	H
Black/Red	Hopper Raise	J
Blue/White	Hopper Lower	K
Green/White	Hoist Raise	L
Black/White	Hoist Lower	N
Blue/Black	Groomer Raise	O
Green/Black	Groomer Lower	P
Red/Black	Level Blade Raise	Q
Orange/Red	Level Blade Lower	S
Black	Ground	B
Orange	Ground	D
Orange/Black	Ground	G
Red/White	Ground	M
Brown (Betts)	12 VDC Power	
White (Betts)	Ground	

ELECTRICAL CONTROL ITEMS NOT SHOWN IN PARTS BOOK:

71.P292050 CONTROL BOX

71.P292100 MAIN HARNESS / CONTROL CABLE

71.470317 POWER SUPPLY CABLE

