

OVERALL LEGEND

REF NO.	PART NO.	DESCRIPTION	QTY
1	002131	VALVE, CONVEYOR DRIVE	1
2	004546	SHIELD, CONV REAR	1
3	004556	SHIELD, CONV CENTER	1
	003815	SCREEN, 1" WIRE	1
	003816	SCREEN, 5/8" WIRE	1
	004593	SCREEN, 1/2" EXPANDED METAL	1
4	003841P	HYD FILTER ASSY (PAGE B)	1
5	005088	TANK, HYD ASSY 800/900 (PAGE B)	1
6	003892	DEPTH CONTROL RIGHT (PAGE D)	1
	003893	DEPTH CONTROL LEFT (PAGE D)	1
7	004171	BRKT, DEPTH ADJ LEFT (PAGE D)	1
	004209	BRKT, DEPTH ADJ RIGHT (PAGE D)	1
8	004680	SHIELD, CONV FRT	1
9	004200	WHEEL RIM 12 X 4	2
10	003839P	TIRE 530 X 12	2
	004267	WHEEL ASSY, GAUGE (INCLUDES 9&10)	2
11	000970P	PIN, COTTER 1/8 X 3	4
12	003587	CONV HOLD DOWN ASSY, RIGHT	1
	003588	CONV HOLD DOWN ASSY, LEFT	1
13	003838P	TIRE 22 X 12.5-9	2
14	004201	WHEEL RIM 9 X 10	2
	004265	WHEEL ASSY, LEFT DRIVE (INCLUDES 13&14)	1
	004266	WHEEL ASSY, RIGHT DRIVE (INCLUDES 13&14)	1
15	004139	DRAG WELD (PAGE F)	1
16	003878	HOPPER DOOR	1
17	004206	SPRING, DRAG	13
18	003883	HOPPER DOOR LATCH	1
19	004524	CHAIN ASSY, DRAG LIFT	2
20	004182	GUARD, CHAIN	1
21	003675P	SWITCH, MOMENTARY (N-ON)	1
22	004149	DRAG LIFT WELD (PAGE F)	1
23	004197	VALVE, SPEED (FWD-REV)	1
24	005136	BAIL WELD	1
25	004196	VALVE, DRIVE	1
	004184	LINKAGE, DRIVE VALVE	1
26	004564P	ENGINE, BRIGGS & STRATTON	1
27	003821P	PUMP MOUNT	1
28	003826P	PUMP, GEAR	1
	003818P	CPLG, DRIVE-ENG	1
	003819P	CPLG, DRIVE-PUMP	1
	003820P	CPLG, INSERT	1
29	005134	HANDLEBAR WELD	1

108026 - 108050 A

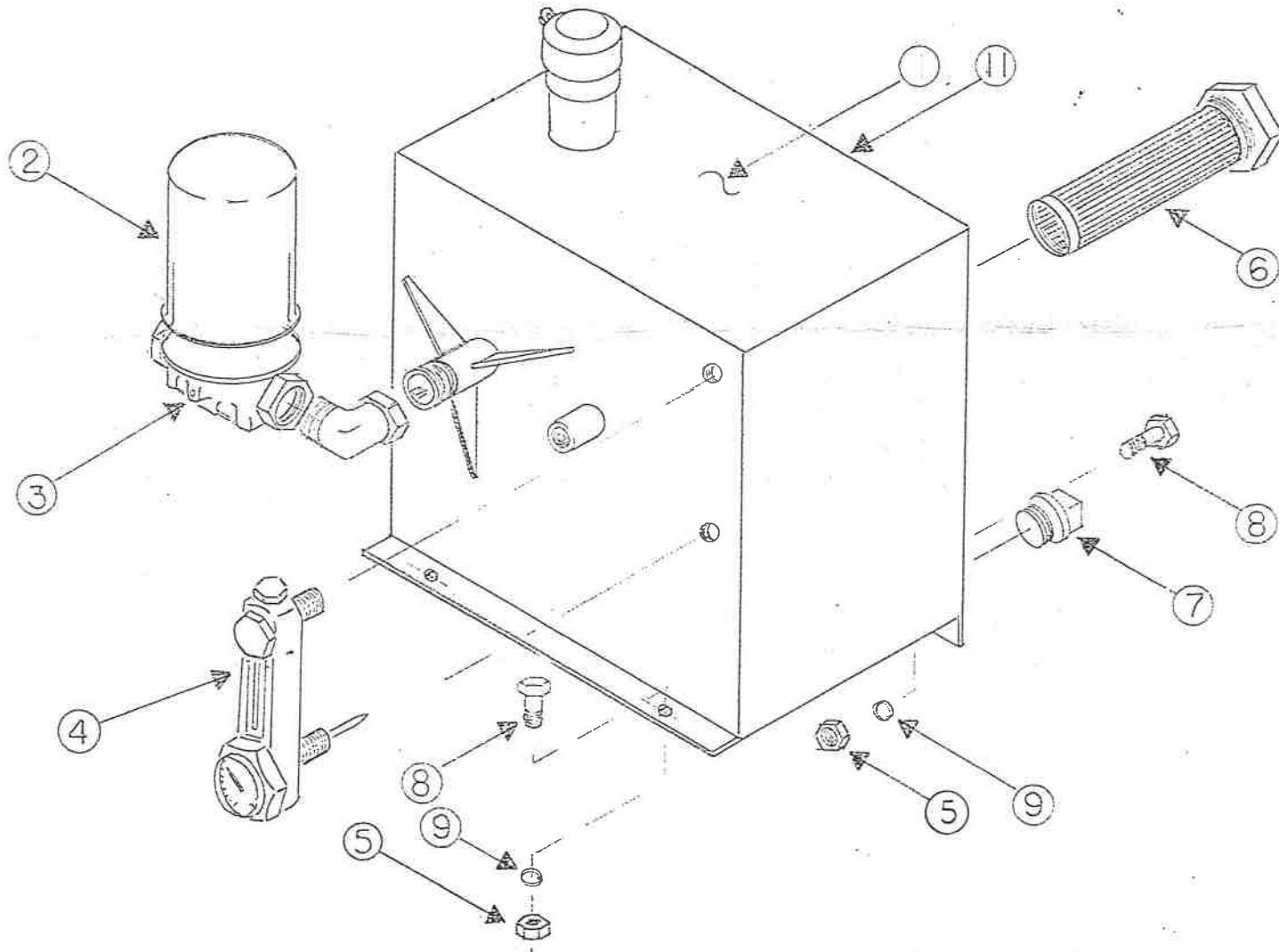

HYDRAULIC OIL TANK

<u>REF NO.</u>	<u>PART NO.</u>	<u>DESCRIPTION</u>	<u>QTY</u>
1	005088	HYDRAULIC TANK ASSY (INCLUDES #6)	1
2	000182P	FILTER, HYDRAULIC	1
3	003841P	HYD. FILTER ASSY (INCLUDES FILTER)	1
4	000176P	GAUGE, OIL SIGHT	1
5	000953P	NUT, LOCK, 3/8-16 NC	4
6	003842P	STRAINER, HYDRAULIC OIL	1
7	001395P	PLUG, PIPE, 1/2"	1
8	000946P	BOLT, 3/8-16 NC X 1	4
9	000955P	WASHER, LOCK, 3/8	4

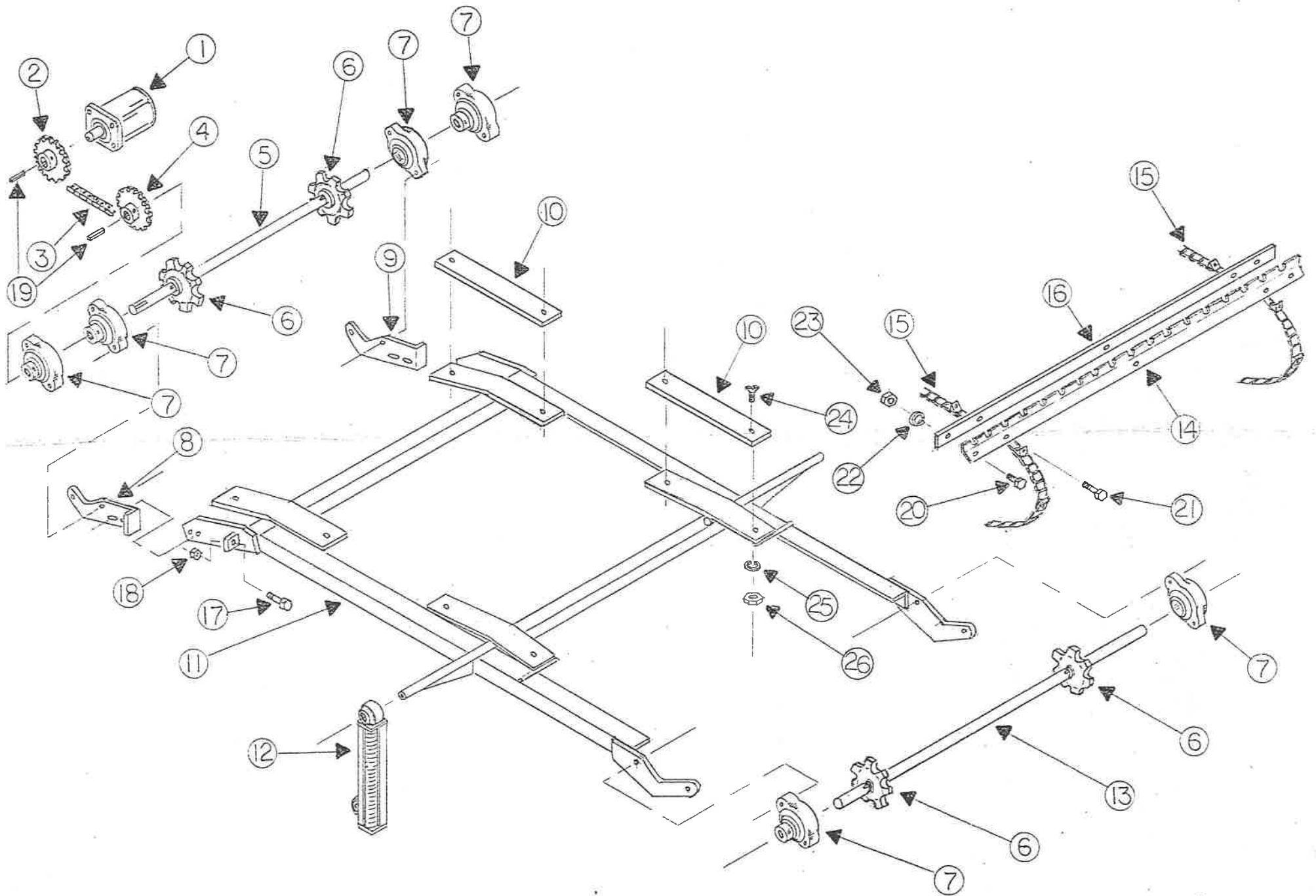

CONVEYOR

REF NO.	PART NO.	DESCRIPTION	QTY
1	003825P	MOTOR, CONVEYOR	1
2	003824P	SPROCKET 50B15F1	1
3	004631	CHAIN, CONV. DRIVE	1
4	004632P	SPROCKET, 50B17F1-1/4	1
	004127	ASSY, SHAFT, REAR CONV. (INCLUDES #5, 2-#6, 4-#7)	1
5	004126	SHAFT, REAR CONV.	1
6	004123	SPROCKET	4
7	003830P	BEARING	6
8	004103	BRKT, CONV. SHAFT ADJ. RH	1
9	004104	BRKT, CONV. SHAFT ADJ. LH	1
10	000271M	WEARSTRIP, CONV.	4
11	004629	CONVEYOR SUPPORT	1
12	003587	CONVEYOR HOLD DOWN ASSY, RH	1
	003588	CONVEYOR HOLD DOWN ASSY, LH	1
13	004122	SHAFT, FRONT, CONV.	1
	004124	ASSY, SHAFT, FRONT CONV. (INCLUDES #13, 2-#6, 2-#7)	1
14	004294	FLIGHT BLADE RH	6
	004295	FLIGHT BLADE LH	6
15	004628	CONVEYOR CHAIN #62-72 LINKS	2
16	004131	FLIGHT BACKUP BAR	12
17	004306P	BOLT, CONV. ADJ.	2
18	000989P	NUT, HEX 1/2-13 ZP	2
19	004125	KEY, 1/4 X 2	2
20	000946P	BOLT, 3/8-16 NC X 1	36
21	000947P	BOLT, 3/8-16 NC X 1-1/4	24
22	000955P	WASHER, LOCK, 3/8	60
23	000953P	NUT, LOCK, 3/8-16 NC	60
24	000924P	BOLT, 5/16-18 X 1 FH MACH SC	8
25	000928P	WASHER, LOCK, 5/16	8
26	000927P	NUT, HEX, 5/16-18 NC	8

D

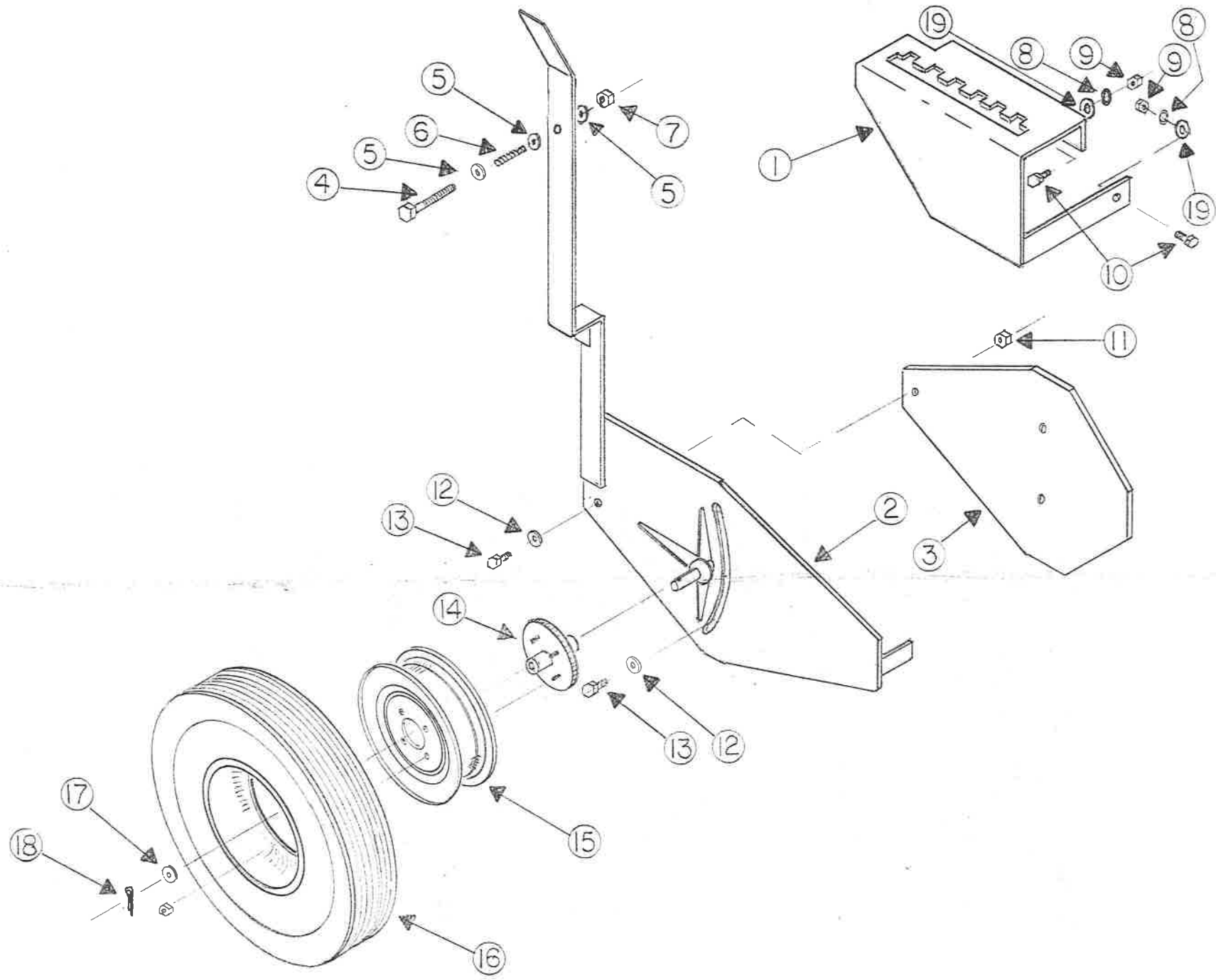

DEPTH ADJUSTMENT ASSY (RH shown)

REF NO.	PART NO.	DESCRIPTION	QTY
1	004209	BRACKET, DEPTH ADJUSTMENT, RH	1
	004271	BRACKET, DEPTH ADJUSTMENT, LH	1
2	003892	DEPTH CONTROL RH	1
	003893	DEPTH CONTROL LH	1
3	004136	WEARPLATE, DEPTH CONTROL	1
4	000925P	BOLT, 5/16-18 NC X 3	1
5	000929P	WASHER, FLAT, 5/16	3
6	004275P	SPRING, CENTURY XX66	1
7	000926P	NUT, LOCK, 5/16-18 NC	1
8	000955P	WASHER, LOCK 3/8	3
9	000953P	NUT, LOCK, 3/8-16 NC	3
10	000946P	BOLT, 3/8-16 NC X 1	3
11	000798P	NUT, JAM 1/2	3
12	000991P	WASHER, FLAT 1/2	3
13	000983P	BOLT, 1/2-13 NC X 1-1/2	3
14	004203	HUB, GAUGE WHL W/STUDS & NUTS	1
15	004200	WHEEL RIM 12 X 4	1
16	003839P	TIRE 530 X 12	1
	004267	WHEEL ASSY, GAUGE (INCLUDES 15 & 16)	1
17	003928P	WASHER, FLAT 3/4	1
18	000970P	PIN, COTTER 1/8 X 3	1
19	000956P	WASHER, FLAT 3/8	3

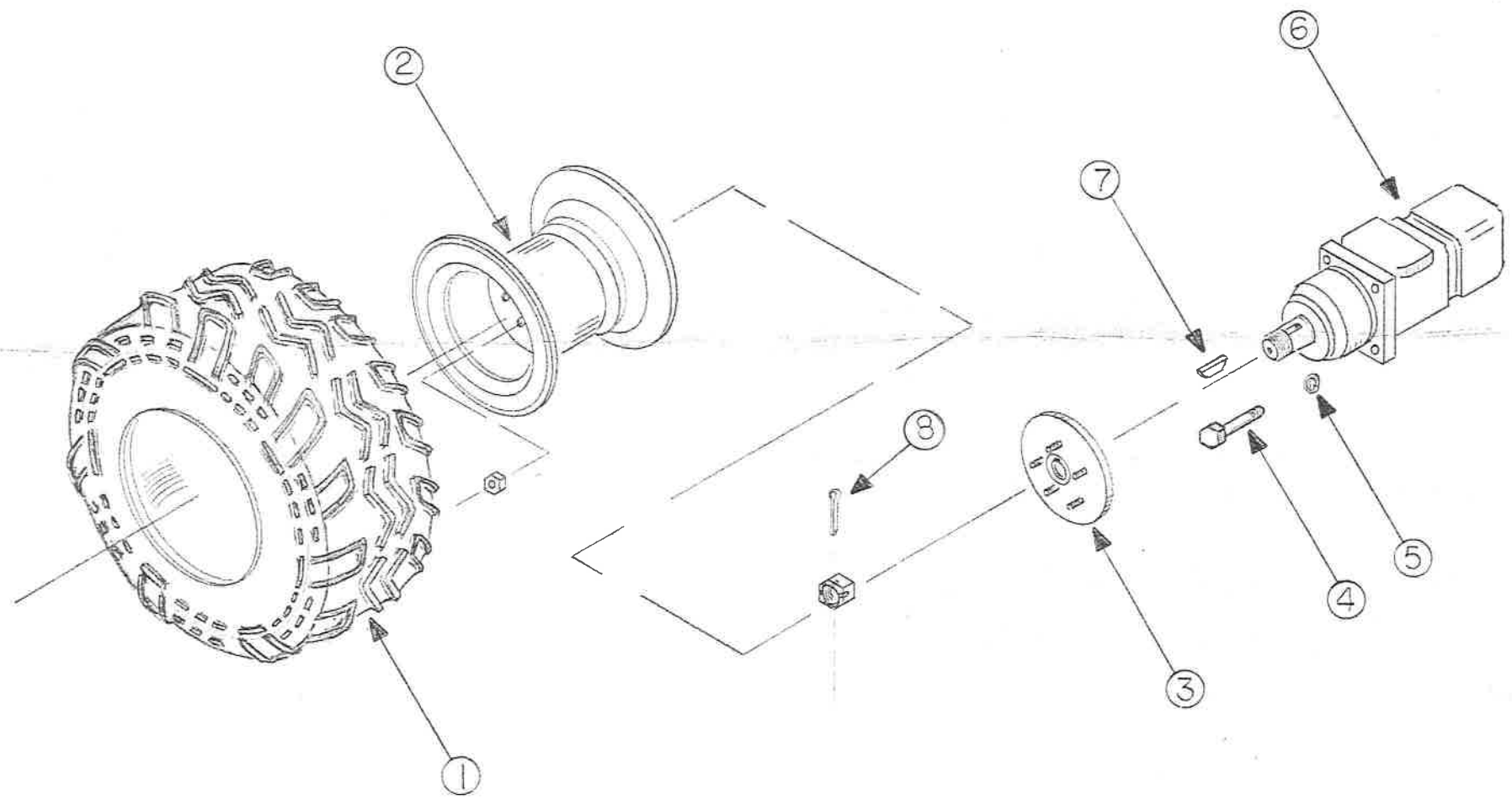

DRIVE WHEEL ASSEMBLY

REF NO.	PART NO.	DESCRIPTION	QTY
1	003838P	TIRE 22 X 12.5-9	1
2	004201	WHEEL RIM 9 X 10	1
	004265	WHEEL ASSY, LEFT DRIVE (INCLUDES 1&2)	1
	004266	WHEEL ASSY, RIGHT DRIVE (INCLUDES 1&2)	1
3	004202	HUB, TAPERED	1
4	000946P	BOLT, 3/8-16 NC X 1	4
5	000955P	WASHER, LOCK, 3/8	4
6	004398P	MOTOR, WHEEL-MF 22.6 CID	1
7	000057P	KEY, WOODRUFF 1/4 X 1 NO. 15	1
8	003946P	PIN, COTTER 3/32 X 2	1

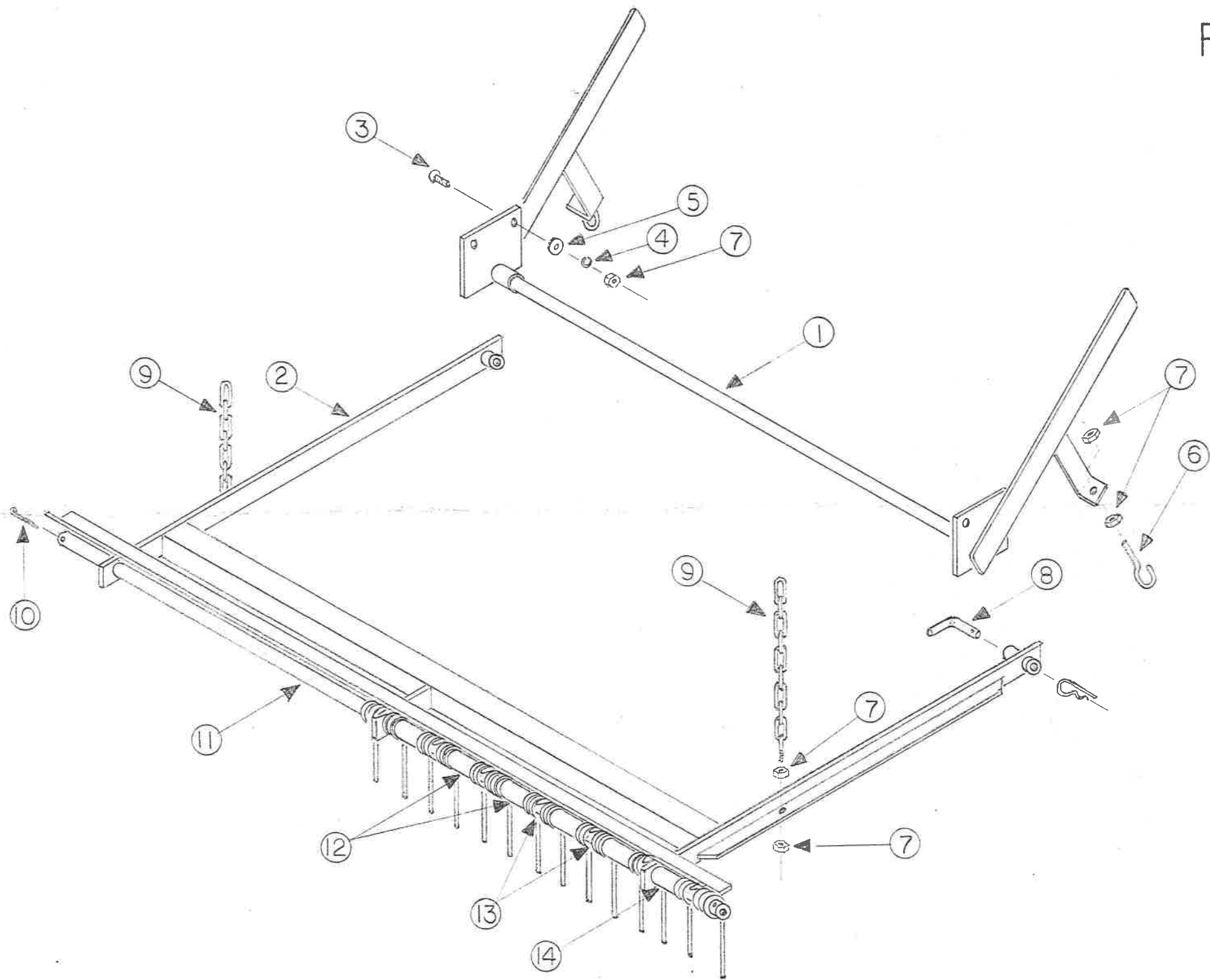

GROOMER ASSY

REF NO.	PART NO.	DESCRIPTION	QTY
1	004149	GROOMER LIFT	1
2	004139	GROOMER WELDMENT	1
3	000924P	BOLT, 5/16-18 X 1 FH MACH SC	4
4	000928P	WASHER, LOCK, 5/16	4
5	000929P	WASHER, FLAT, 5/16	4
6	004269	EYEBOLT, 5/16 OPEN	2
7	000927P	NUT, HEX, 5/16-18 ZP	12
8	004268P	PIN, BENT HITCH 1/2 X 2-1/2	2
9	004524	CHAIN ASSY, DRAG LIFT	2
10	000970P	PIN, COTTER 1/8 X 3	2
11	004144	PIPE, SPRING MT., GROOMER	1
12	004176	SPACER, GROOMER, LARGE	10
13	004206	SPRING, DRAG	13
14	004177	SPACER, GROOMER, SMALL	2

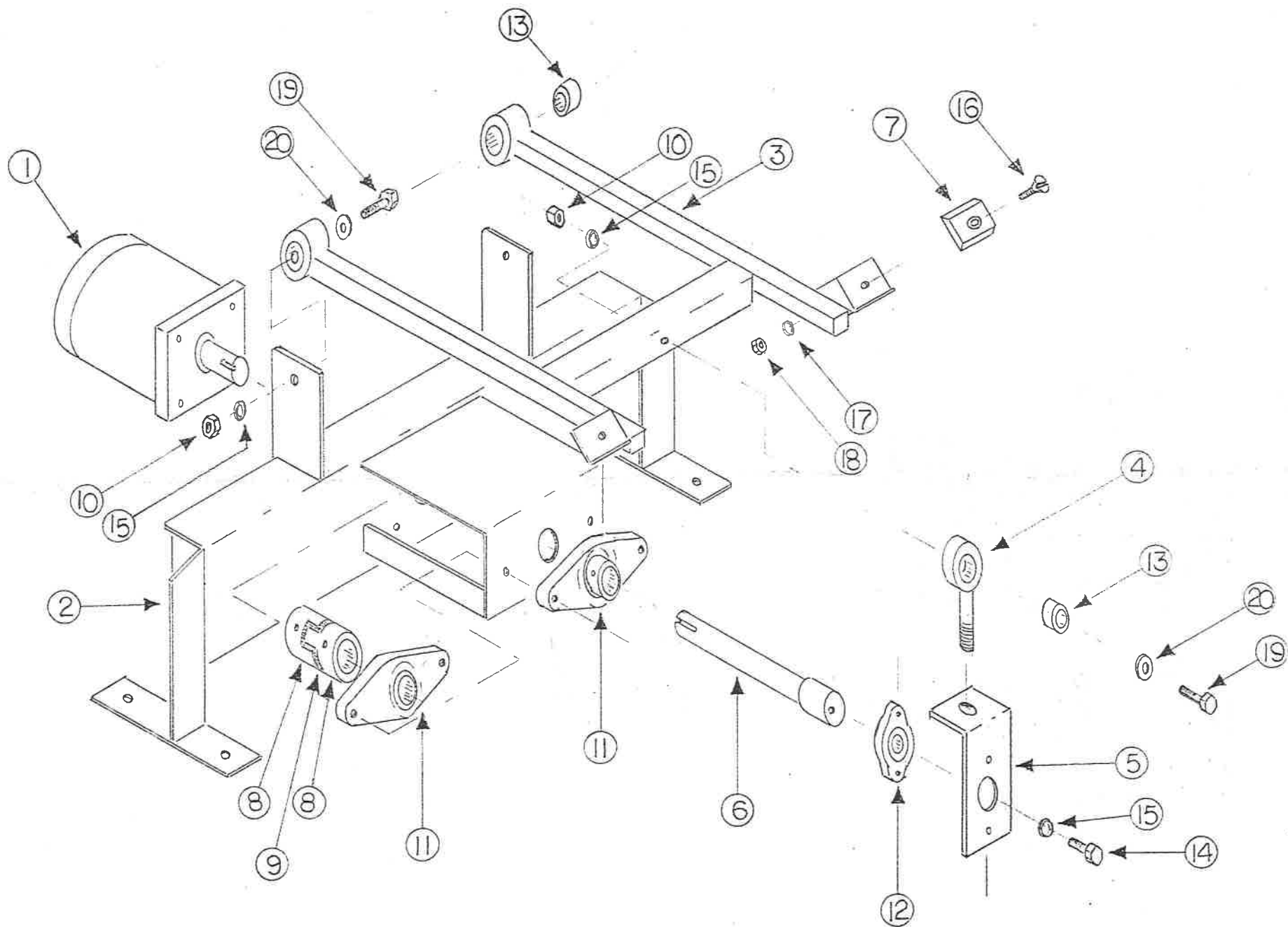

/SEPARATOR

<u>REF NO.</u>	<u>PART NO.</u>	<u>DESCRIPTION</u>	<u>QTY</u>
1	004618P	MOTOR, SEPARATOR	1
2	004613	FRAME, SEPARATOR	1
3	004605	ARM, SEPARATOR	1
4	004599	LINK, SOCKET WELD	1
5	004600	BRKT, SEPARATOR LINK	1
6	004596	SHAFT, CAM WELD	1
7	004597	WEAR PAD, SEPARATOR	2
8	003818P	CPLG, DRIVE	2
9	003820P	CPLG, INSERT	1
10	000988P	NUT, LOCK, 1/2-13 NC	3
11	004622	BEARING, 1" FLANGE	2
12	004623	BEARING, 1/2" FLANGE	1
13	003319P	BUSHING, RUBBER 1.12 X 1	3
14	000984P	BOLT, 1/2-13 NC X 1-3/4	1
15	000990P	WASHER, LOCK 1/2	4
16	000924P	BOLT, 5/16-18 X 1 FH MACH SC	2
17	000928P	WASHER, LOCK 5/16	2
18	000927P	NUT, HEX 5/16-18	2
19	000985P	BOLT, 1/2-13 NC X 2	3
20	000991P	WASHER, FLAT 1/2	3

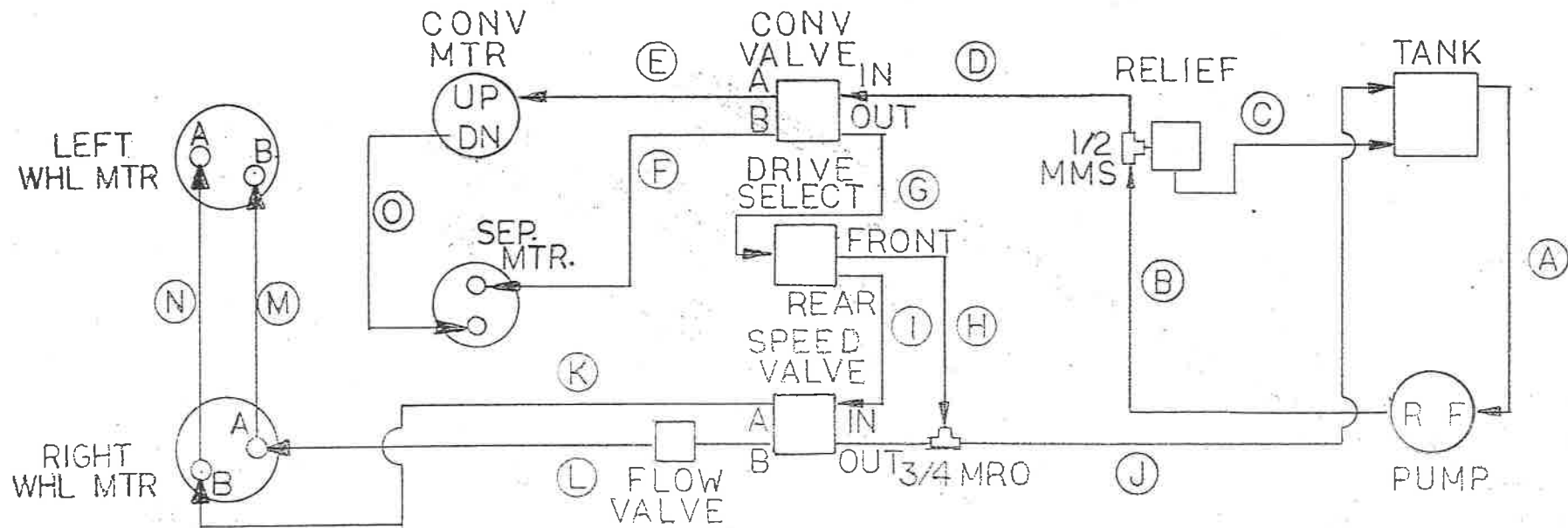

- A 1" CD, 1X3/4 PTR, ZINGA FT0710ZP, H1172P, ZINGA FT0710ZP, 1X3/4 PTR, AE40G 16-1
- B 0507-10-8, 3107-8-8, 3107-8-8, H1027P, 3107-8-8, 1/2" MMS, 0507-8-8
- C 3507-8-8, H1169P, 2107-8-8
- D 2107-8-8, H1168P, 3107-8-8, 3107-12-8
- E 2107-8-8, H1024P, 3507-10-8
- F 2107-8-8, H1179P, 2507-10-8
- G 2107-12-8, H1168P, 2507-8-8
- H 3507-8-8, H1024P, 2107-12-8
- I 3507-8-8, 3107-8-8, H1168P, 2107-12-8
- J 3107-12-12, 3/4 MRO, 3107-12-12, H1171P, 2507-12-12, FILTER, AEOG12-3/4
- K 2107-8-8, H1136P, 2107-8-8, 1/2" MRO, 0507-8-8
- L CR 1/2", FLOW VALVE, 0107-8-8, H1170P, 2107-8-8, 1/2" MRO, 0507-8-8
- M 3107-8-8, H1140P, 2507-8-8
- N 3107-8-8, H1140P, 2507-8-8
- O 3507-10-8, H1178P, 2107-8-8, 0507-10-8

BEGAN ON _____
 PER ECO/BOMCO# _____

REPLACED 001491
 ON 108026 PER# 99-019

REPLACED BY _____
 ON _____ PER# _____

001495

HYDRAULIC DIAGRAM,
 900